

Gemina Termix A/S
Navervej 15-17
DK-7451 SUNDS
Danmark

Testing of a HIU according to the UK HIU Test Regime

(2 appendices)

1 Assignment

RISE has tested a heat interface unit (HIU) (also known as a district heating substation) from SAV on behalf of Gemina Termix.

This report, 7P03675A-rev1, replaces report 7P03575A from 2017-08-15. The current version includes changes to section 3 (Test object).

2 Test method

The test method is described in the UK HIU Test Regime Technical Specification, Rev-007, issued by the Building Engineering Services Association (BESA). This will be referred to as the Test Regime throughout this document.

The Test Regime specifies testing according to two different test packages: High temperature, with a primary supply temperature of 70 °C, and Low temperature, with a primary supply temperature of 60 °C. The current test object was tested according to the High temperature test package.

3 Test object

Manufacturer: Gemina Termix A/S
Model name: VVX-I-R FI 1-2 RAD
Type/serial number: L7020419
Year of manufacture: 2017
Domestic hot water priority: no

3.1 Design pressures

Primary side: 10 bar
Secondary side, space heating: 6 bar
Secondary side, DHW: 10 bar
Maximum differential pressure, primary side: 6 bar

3.2 Design temperatures

Primary side: max 110 °C
Secondary side, space heating: dimensioned for 35-75 °C
Secondary side, DHW: dimensioned for 65 °C

RISE Research Institutes of Sweden AB

Postal address
Box 857
SE-501 15 BORÅS
Sweden

Office location
Brinellgatan 4
SE-504 62 BORÅS

Phone / Fax / E-mail
+46 10 516 50 00
+46 33 13 55 02
info@ri.se

This document may not be reproduced other than in full, except with the prior written approval of RISE.

Figure 1. The test object after testing. Insulation removed.



3.3 Components and documentation

See Appendix 1.

4 Test location and time

The testing was performed at RISE in Borås, Sweden, section of Energy and circular economy, in May – July 2017. The test object arrived to RISE on the 2nd of May 2017 with no visible damage.

5 Abbreviations

Term	Meaning (<i>diagram legend entry</i>)	
DHW	Domestic hot water	-
HIU	Heat Interface Unit	-
SH	Space heating	-
P₁	Heat load, primary side	[kW]
P₂	Heat load, space heating system	[kW]
P₃	Heat load, domestic hot water	[kW]
t₁₁	Temperature, primary side supply connection (<i>DH supply</i>)	[°C]
t₁₂	Temperature, primary side return connection (<i>DH return</i>)	[°C]
t₂₁	(Temperature, space heating system return connection (<i>SH return</i>))	[°C]
t₂₂	Temperature, space heating system supply connection (<i>SH supply</i>)	[°C]
t₃₁	Temperature, cold water (<i>CWS</i>)	[°C]
t₃₂	Temperature, domestic hot water supply connection (<i>DHW supply</i>)	[°C]
q₁	Volume flow, primary side (<i>DH</i>)	[l/s]
q₂	Volume flow, space heating system (<i>SH</i>)	[l/s]
q₃	Volume flow, domestic hot water (<i>DHW</i>)	[l/s]
Δp₁	Primary pressure drop across entire HIU unit	[bar]
Δp₂	Pressure drop, space heating system across HIU	[kPa]
Δp₃	Pressure drop, domestic hot water across HIU	[kPa]

6 Test equipment

The following equipment has been used during the tests:

District heating test rig FV3	ETu-QD CB:11
Differential pressure meter	Inv. no. 202 111
Differential pressure meter	Inv. no. 202 112
Differential pressure meter	Inv. no. 202 680
Flow meter, inductive, DN 15	Inv. no. 202 082
Flow meter, inductive, DN 15	Inv. no. 202 688
Flow meter, inductive, DN 15	Inv. no. 202 686
Flow meter, inductive, DN 4	Inv. no. BX60131
Logger for measured data	Inv. no. 202 879
Pressure meter for pressure test	Inv. no. 201 378

RISE Test rig FV/3

Setup for the UK HIU Test Regime

Figure 2. Simplified schematic of the test rig used for the tests.

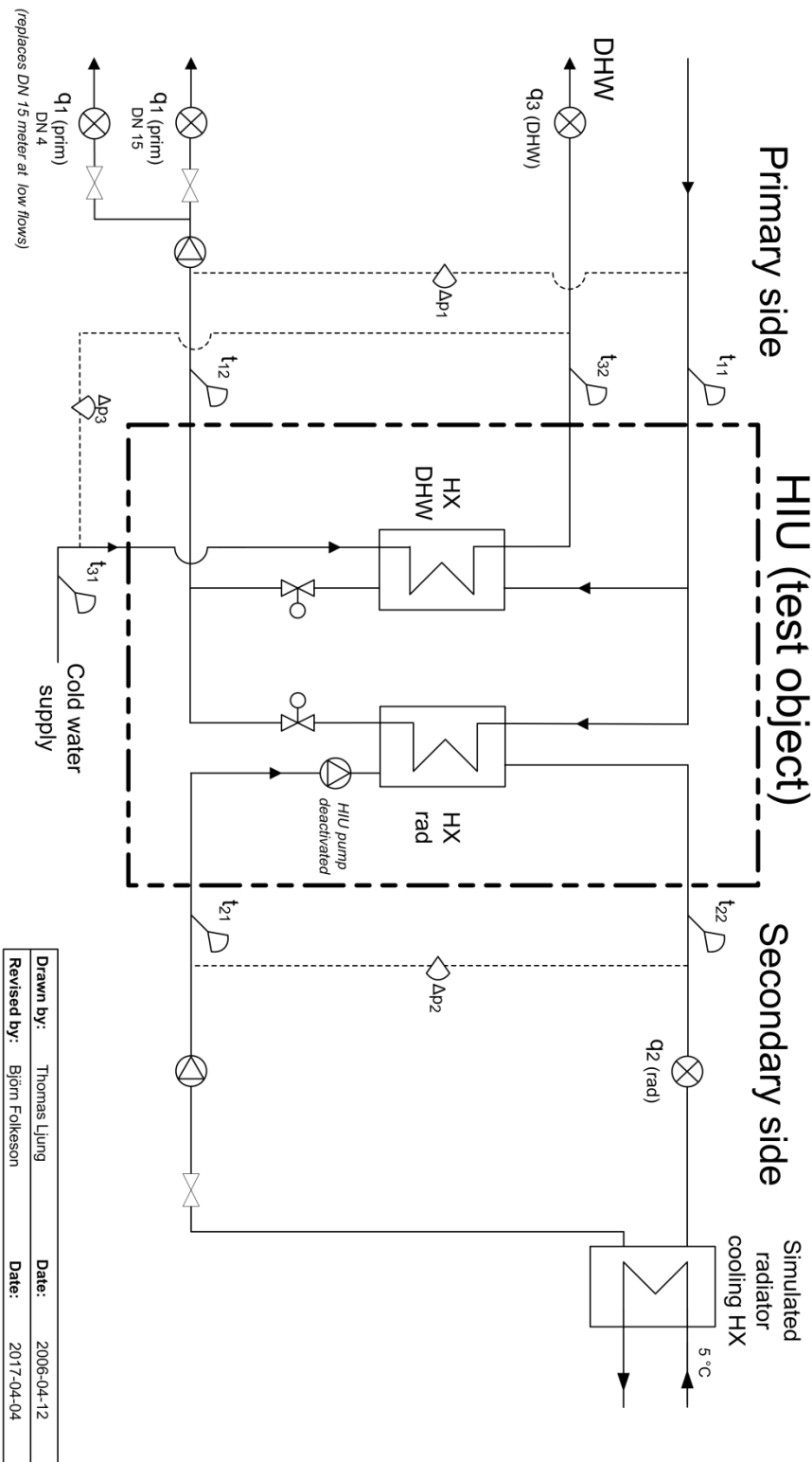

Drawn by:	Thomas Ljung	Date:	2006-04-12
Revised by:	Björn Folkesson	Date:	2017-04-04

6.1 Collection of measurement data, static measurements

When conditions were stable, measurement results were registered for at least 300 seconds. Registered static measurement test values are averages of 300 data points. Sampling rate was 1 Hz for static tests. The pressure in the space heating circuit was 1.5 bar.

6.2 Collection of measurement data, dynamic measurements

Sampling rate was 1 Hz for dynamic measurements.

The time constant for the temperature sensors in the measuring point t_{32} is ≤ 1.5 s and represents 63% of the final value of a momentary change of temperature from 10 to 90 °C.

The time constant for the flow meter to measure the DHW flow is ≤ 0.2 s.

The pressure for the incoming cold water was 1.5 bar for the production of DHW in direct heat exchanging.

For the control of DHW flow the test rig has two parallel coupled solenoid valves. Each solenoid valve controls a set flow.

Results are presented in chart form and are verified with numerical values.

6.3 Control systems for DHW

The tested HIU is intended for direct exchange of DHW. This means that the incoming cold water (10 ± 0.5 °C), is heated directly in the heat exchanger to DHW temperature. The temperature of DHW in the measuring point t_{32} was measured in connection to the HIU DHW tap.

6.4 Measurement uncertainty

The measurement uncertainty has been estimated to be better than following values:

Differential pressure, primary	± 10 kPa
Differential pressure, space heating	± 1 kPa
Differential pressure, tap water	± 1 kPa
Temperature 0-100 °C	± 0.1 °C
Flow, primary (0.06-0.5 l/s)	± 1.5 %
Flow, primary (< 0.06 l/s)	± 4.0 %
Flow, space heating (0.06-0.5 l/s)	± 1.5 %
Flow, tap water (0.02-0.4 l/s)	± 1.5 %
Power ($\Delta t=10.0$ °C)	± 2.1 %
Power ($\Delta t=20.0$ °C)	± 1.7 %
Pressure 0-7 MPa	± 10 kPa

The measurement uncertainty has been calculated according to EA-4/16 with a coverage factor $k=2$.

7 Test results

The test results apply only to the tested unit.

The results of each test are presented as specified in the Test Regime. Refer to Table 1 regarding the test setup and Table 2 for details on the reporting.

Table 1. Test setup. Extract from the Test Regime.

No	Test	static pressure on return	dP across HIU	Primary flow temp	DHW setpoint	DHW flow rate	DHW power	SH output	SH flow temp	SH return temp
		[bar]	dP ₁ [bar]	t ₁₁ [°C]	t ₃₂ [°C]	q ₃ [l/s]	P ₃ [kW]	P ₂ [kW]	t ₂₂ [°C]	t ₂₁ [°C]
Static tests										
0a	Static pressure test (same static pressure on both flow and return connections)	1.43 times rated value	1.43 times rated value	n/a	n/a	n/a	n/a	n/a	n/a	n/a
0b	Differential pressure test (DH flow at higher pressure than DH return)	1.43 times rated value	1.43 times rated value	n/a	n/a	n/a	n/a	n/a	n/a	n/a
1a	Space Heating 1 kW (DH 70°C flow)	2.5	0.5	70	55	0	0	1	60	40
1b	Space Heating 2 kW (DH 70°C flow)	2.5	0.5	70	55	0	0	2	60	40
1c	Space Heating 4 kW (DH 70°C flow)	2.5	0.5	70	55	0	0	4	60	40
1d	Space heating 1 kW (DH 60°C flow)	2.5	0.5	60	50	0	0	1	45	35
1e	Space heating 2 kW (DH 60°C flow)	2.5	0.5	60	50	0	0	2	45	35
1f	Space heating 4 kW (DH 60°C flow)	2.5	0.5	60	50	0	0	4	45	35
Dynamic tests										
2a	DHW only (DH 70°C flow)	2.5	0.5	70	55	DHW test profile	DHW test profile	0	n/a	n/a
2b	DHW only (DH 60°C flow)	2.5	0.5	60	50	DHW test profile	DHW test profile	0	n/a	n/a
3a	Low flow DHW (DH 70°C flow)	2.5	0.5	70	55	0.02	Record value	0	n/a	n/a
3b	Low flow DHW (DH 60°C flow)	2.5	0.5	60	50	0.02	Record value	0	n/a	n/a
4a	Keep-warm (DH 70°C flow)	2.5	0.5	70	55	0	0	0	n/a	n/a
4b	Keep-warm (DH 60°C flow)	2.5	0.5	60	50	0	0	0	n/a	n/a
5a	DHW response time (DH 70°C flow)	2.5	0.5	70	55	0.13	Record value	0	n/a	n/a
5b	DHW response time (DH 60°C flow)	2.5	0.5	60	50	0.13	Record value	0	n/a	n/a

The cold water supply to the HIU on the test rig shall be 10 °C and at 1.5 bar for all tests.

Table 2. Reporting of test results. Extract from the Test Regime.

Test	Description	Reporting
Static tests		
0	Pressure tests	Pass/Fail as to whether HIU manages pressure test without leaks or damage
1a	Space Heating 1 kW, 60/40 °C secondary	t ₁₂ - primary return temperature. Plot of key metrics over duration of test. Note: Outputs readings used as input data to 'High Temperature' Space Heating Weighted Average Return Temperature calculation.
1b	Space Heating 2 kW, 60/40 °C secondary	
1c	Space Heating 4 kW, 60/40 °C secondary	
1d	Space Heating 1 kW, 45/35 °C secondary	t ₁₂ - primary return temperature. Plot of key metrics over duration of test. Note: Outputs readings used as input data to 'Low Temperature' Space Heating Weighted Average Return Temperature calculation.
1e	Space Heating 2 kW, 45/35 °C secondary	
1f	Space Heating 4 kW, 45/35 °C secondary	
Dynamic tests		
2a	DHW only, DH 70 °C flow, 55 °C DHW	Pass/Fail on DHW exceeding 65°C (at t ₃₂) for more than 10 seconds. Comment on stability of DHW temperature. Assessment of scaling risk, based on extent and duration of temperatures in excess of 55°C. Plot of key metrics over duration of test. Note: Outputs used as input data to 'High Temperature' Domestic Hot Water Volume Weighted Average Return Temperature calculation.
2b	DHW only, DH 60 °C flow, 50 °C DHW	Assessment of whether return temperatures remain under control at the lower flow temperature. Assessment of scaling risk, based on extent and duration of temperatures in excess of 55°C. Plot of key metrics over duration of test. Note: Outputs used as input data to 'Low Temperature' Domestic Hot Water Volume Weighted Average Return Temperature calculation.
3a	Low flow DHW, DH 70°C flow; 55 °C DHW	Pass/Fail on DHW exceeding 65°C (at t ₃₂) for more than 10 seconds. Pass/Fail on DHW maintaining 55°C±3°C (at t ₃₂) for 60 seconds. Assessment of scaling risk, based on extent and duration of temperatures in excess of 55°C Commentary if DHW supply not stable. Plot of key metrics over duration of test.
3b	Low flow DHW, DH 60°C flow; 50 °C DHW	Pass/Fail on DHW maintaining 50°C±3°C (at t ₃₂) for 60 seconds. Assessment of scaling risk, based on extent and duration of temperatures in excess of 55°C Commentary if DHW supply not stable. Plot of key metrics over duration of test.
4a	Keep-warm. DH 70°C flow; 55 °C DHW	Assessment of whether valid keep-warm operation, based on 5a response time criteria: Pass / Fail. Observation on the operation of the HIU during keep-warm. Assessment of scaling risk, based on extent and duration of temperatures in excess of 55°C. Comment on HIU keep-warm controls options. Plot of key metrics over duration of test. If cycling is observed, plot of the key metrics over the duration of a typical keep-warm cycle. State heat loss in Watts. State primary flowrate. Note: Outputs used as input data to 'High Temperature' Keep-warm Volume

Test	Description	Reporting
		Weighted Average Return Temperature calculation
4b	Keep-warm, DH 60°C flow; 50°C DHW	Assessment of whether valid keep-warm operation, based on 5a response time criteria: Pass / Fail. Observation on the operation of the HIU during keep-warm. Assessment of scaling risk, based on extent and duration of temperatures in excess of 55°C. Comment on HIU keep-warm controls options. Plot of key metrics over duration of test. If cycling is observed, plot of the key metrics over the duration of a typical keep-warm cycle. State heat loss in Watts. State primary flowrate. Note: Outputs used as input data to 'Low Temperature' Keep-warm Volume Weighted Average Return Temperature calculation
5a	DHW response time, DH 70°C flow; 55°C DHW	Pass/Fail on DHW exceeding 65°C (at t_{32}) for more than 10 seconds. State time to achieve 45°C (at t_{32}) and not subsequently drop below 42°C. Comment on stability of DHW temperature. Plot of key metrics over duration of test.
5b	DHW response time, DH 60°C flow; 50°C DHW	State time to achieve 45°C (at t_{32}) and not subsequently drop below 42°C. Comment on stability of DHW temperature. Plot of key metrics over duration of test.

7.1 Test 0: Pressure tests

During the static pressure test 0a, the tightness of the components on the primary side of the HIU has been checked. This has been performed by closing the primary return and pressurizing the primary flow with 14.3 bar (1.43 times the construction pressure) for 30 minutes. During this test the pressure in the space heating circuit and the pressure on incoming cold water was 1.5 bar.

During the differential pressure test 0b, the tightness of the space heating control valve and the DHW control valve has been checked. This has been performed by pressurizing the primary flow to 8.6 bar (1.43 times the maximum differential pressure) for 30 minutes with the primary return open and the space heating control valve and the DHW control valve closed. During this test the pressure in the space heating circuit and the pressure on incoming cold water was 1.5 bar.

Test requirement: The HIU is to manage the pressure tests without leaks or damage.
Result: Pass.

7.2 Test 1a-1c: Space Heating 1-4 kW

For test points 1a-1c a space heating load of 1-4 kW was simulated using a heat exchanger on the test rig. The HIU pump was deactivated and the space heating flow was adjusted in the test rig to deliver the required space heating load. The pressure in space heating circuit was 1.5 bar for all tests.

While the HIU was delivering 4 kW of space heating, the space heating flow temperature t_{22} was adjusted on the HIU until it reached 60 ± 0.5 °C as measured by the test rig. The space

heating return temperature t_{21} was 40 °C. The primary flow temperature t_{11} was 70 °C. The pressure in the space heating circuit was set to 1.5 bar. For further details regarding the test setup, see Table 1.

During test 1a-1c the setting for space heating supply temperature t_{22} on the HIU space heating thermostat was approx. 4.

The results of the test points 1a-1c are presented in Table 3 as averages of 300 data points. The results are also presented in Figure 3 to Figure 5, appendix 2.

Table 3. Test results for test points 1a-1c.

Test point	Primary				Secondary				
	t_{11}	t_{12}	q_1	P_1	t_{21}	t_{22}	q_2	Δp_2	P_2
	[°C]	[°C]	[l/s]	[kW]	[°C]	[°C]	[l/s]	[kPa]	[kW]
1a	70.0	40.8	0.009	1.1	39.8	60.0	0.011	1.0	1.0
1b	69.9	41.2	0.018	2.2	39.8	59.7	0.025	2.9	2.0
1c	70.0	41.8	0.037	4.3	39.8	59.9	0.049	8.8	4.1

7.3 Test 2a: DHW only, DH 70 °C flow

In test point 2a a dynamic test of DHW was performed according to DHW flow rates specified in the Test Regime. The primary flow temperature t_{11} was 70 °C. The DHW setpoint was adjusted while the HIU delivered 0.13 l/s of DHW until the DHW temperature t_{32} reached 55 ± 0.5 °C as measured by the test rig. The setting for DHW supply temperature on the HIU DHW control valve was approx. 2.1. For further details regarding the test setup, see Table 1.

The DHW temperature (t_{32}) exceeded 55 °C for a total of 727 seconds during the test.

The DHW temperature (t_{32}) did not exceed 65 °C during the test. The highest measured temperature in point t_{32} was 56.9 °C. Between 200 and 2160 seconds, the lowest measured temperature in point t_{32} was 52.0 °C.

Test requirement: The DHW flow temperature t_{32} is not to exceed 65 °C for more than 10 seconds.

Result: Pass.

The test results for test point 2a are presented in Figure 6, appendix 2.

7.4 Test 3a: Low flow DHW, DH 70 °C flow

In test point 3a a low DHW flow of 0.02 l/s was tested. The primary flow temperature t_{11} was 70 °C and the domestic hot water setpoint was 55 °C. For further details regarding the test setup, see Table 1.

The DHW temperature (t_{32}) exceeded 55 °C total of 300 seconds during the test.

The DHW temperature (t_{32}) did not exceed 65 °C during the test. For a 60 second period, the primary flow q_1 varied between 62 and 64 l/h while t_{32} varied between 57.7 and 57.8 °C.

Test requirement: The DHW flow temperature t_{32} is not to exceed 65 °C for more than 10 seconds.

Result: Pass

Test requirement: The DHW flow temperature t_{32} is to be maintained within $55 \pm 3^\circ\text{C}$ for 60 seconds.

Result: Pass

The results of the test point 3a are presented in Figure 7, appendix 2.

7.5 Test 4a: Keep-warm, DH 70 °C flow

In test point 4a the standby characteristics of the HIU were tested. A DHW flow of 0.13 l/s was drawn until stable conditions were reached and was then turned off. Data was then collected for 8 hours. For further details regarding the test setup, see Table 1.

The standby performance of the HIU is dependent on the standby control method used. The HIU had no specific settings for the standby function.

If the difference between the maximum and minimum primary flow temperature t_{11} is higher than 6 °C during the final 3 hours of the test the HIU is considered to perform keep-warm cycling. The temperature difference between the maximum and minimum primary flow temperature t_{11} during the final 3 hours of the test was 0.8 °C and as such the HIU was not considered to perform keep-warm through cycling. The validity of the keep-warm facility is evaluated in test point 5a.

During the 8 hours after turning off the domestic hot water flow the average primary flow q_1 was 4 l/h and the average heat load P_1 was 31 W.

The DHW temperature (t_{32}) did not exceed 55 °C during the test.

The results of the test point 4a are presented in Figure 8, appendix 2.

7.6 Test 5a: DHW response time, DH 70 °C flow

Immediately after test point 4a, test point 5b was carried out. A DHW flow of 0.13 l/s was drawn until conditions were stable. For further details regarding the test setup, see Table 1.

The DHW response time might be dependent on the HIU keep-warm settings. See Test 4a: Keep-warm, DH 70 °C flow.

The DHW temperature (t_{32}) did not exceed 65 °C during the test. The DHW temperature (t_{32}) reached 45 °C 4 seconds after the DHW flow was started and did not drop below 42 °C thereafter.

Test requirement: The DHW flow temperature t_{32} is not to exceed 65 °C for more than 10 seconds.

Result: Pass.

Test requirement: the keep-warm facility is considered valid if the DHW temperature t_{32} reaches 45 °C within 15 seconds.

Result: Pass.

The results of the test point 5a are presented in Figure 9, appendix 2.

RISE Research Institutes of Sweden AB
Energy and circular economy - Sustainable Supply Systems and Plastic Products

Performed by

Examined by

Björn Folkesson

Anna Boss

Appendices

1. Component data and documentation
2. Diagrams

Appendix 1

Appendix 1. Component data and documentation

Component	Documentation submitted? (Yes/No)	Manufacturer and type
Circulation pump	Yes	Grundfos UPM3 Auto L 15-70
Control valve and actuator for domestic hot water	Yes	IHPT kvs 3.0 003L3932
Thermostat for space heating	Yes	RAVK 35-75°C 003L3531
Space heating valve	Yes	VMT 15.8 kvs 1.5 065F0115
Space heating zone valve	Yes	Termoaktuator TWA-V NC 088H3122
Differential pressure control valve	Yes	Danfoss AVPL DN15 kvs 1.0 003L5030
Domestic hot water isolating valve/check valve	Yes	Watts IN020 DN 20
Domestic hot water heat exchanger	Yes	XB06H+ - 1 26 H G3/4"*10 004B1212
Drain valves	Yes	Kuglevent. 1/2" N.N. 18090000
Expansion vessel	Yes	CIMM RP 200 8 litres
Gaskets	Yes	Dana Victor Reinz AFM 34
Heat meter (if present, otherwise 25 kPa restrictor is installed)	Yes	Danfoss Sonometer 1100 kvs 1.5 087G1041
Joints and connections	Yes	Glue: Henkel Omnifit 1790 Brass nuts: Omløber 3/4*18,5*H13 NV30 mess
Manometer	Yes	IMIT 0-4 bar Manometro circolare mod. 964/A 066226
Pipes	Yes	18 mm/1 mm ANSI 304
Primary side strainer	Yes	Termix Snavs. 3/4"N.N. m/følerlomme N18127741
Safety valves (pressure relief valves)	Yes	Watts MSL 2.5 bar 1/2" MBSP x FBSP
Shock absorber (if present)	Yes	FAR Anti-water hammer PN10 Tmax 90 °C
Space heating heat exchanger	Yes	XB06H+ - 1 8 G3/4"*20
Space heating strainer	Yes	Termix Snavssamler 3/4" N.N. Mess. 18126300
Temperature sensors	-	Integrated in IHPT
Thermometer	-	N/A
Vent valves	Yes	Termix Air Relief Screw 22247018
Safety thermostat (temperature controlled)	Yes	IMIT Thermostat BRC545810

Appendix 1

Documentation		Document
Commissioning guide/Installation guide	Yes	Operating guide Termix VVX-I-R FI - 7 Series DS fully insulated (LGB40448)
Declaration of Conformity for CE-marked HIU:s	Yes (Machinery Directive, LVD, EMC)	In Operating guide
Details of calculation programs used for the heat exchangers	Yes	Danfoss Hexact 3.4.13
Full parameter list for electronically controlled HIU:s	-	N/A
Operation guide with a function description/description of operations and care instructions as suited to the intended user category	Yes	In Operating guide
Schematic diagram and drawing showing the structure and arrangement of the HIU with dimensions and weight	Yes	UK99448952 Termix-I-R FI RAD with IHPT UP Std. UK (simplified version with weight data in Operating guide)
Technical specification for electronic components including version of software	-	N/A

Appendix 2

Appendix 2. Diagrams

Figure 3. Results for test point 1a: space heating 1 kW, DH 70 °C supply.

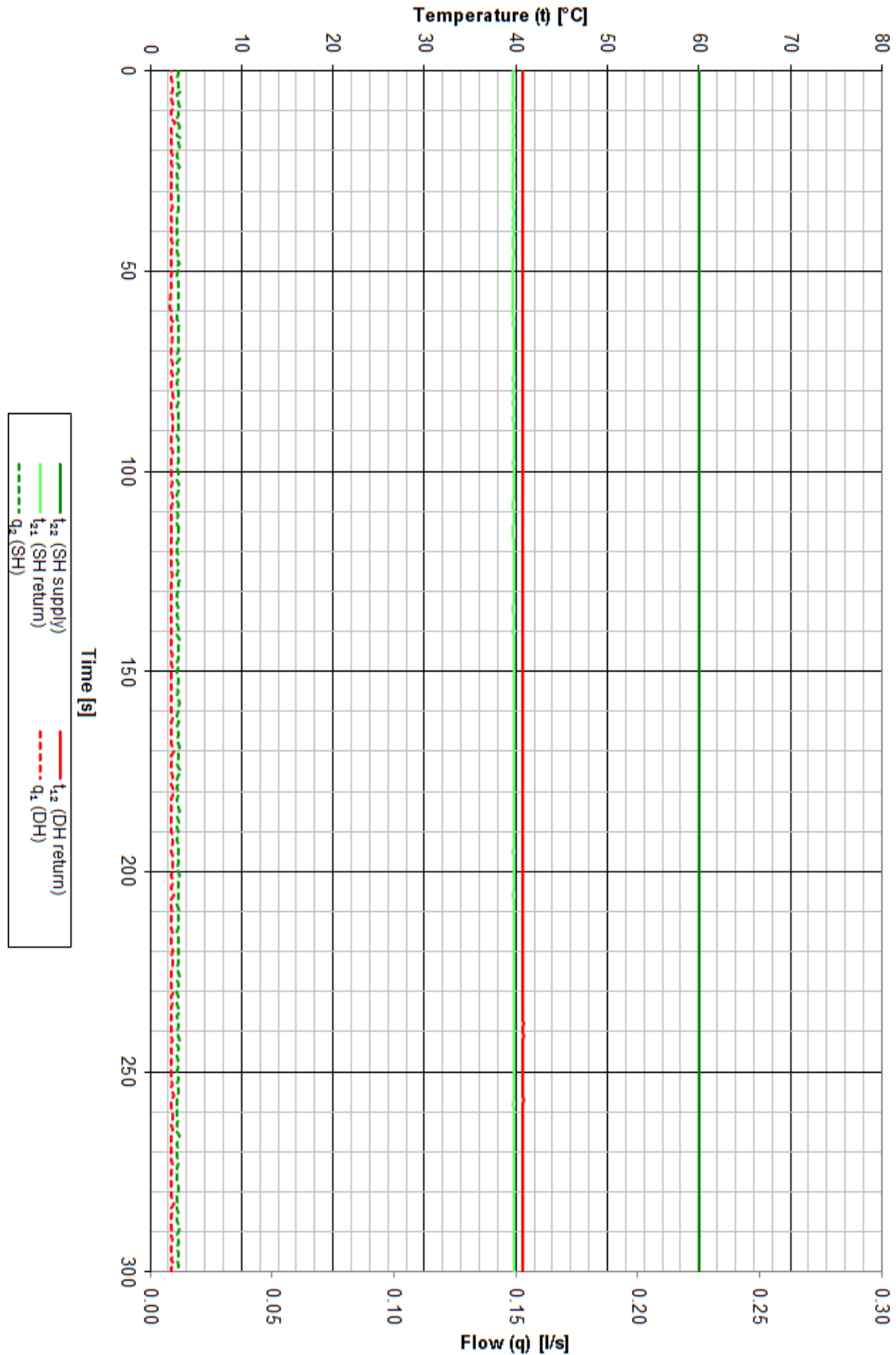

Appendix 2

Figure 4. Results for test point 1b: space heating 2 kW, DH 70 °C supply.

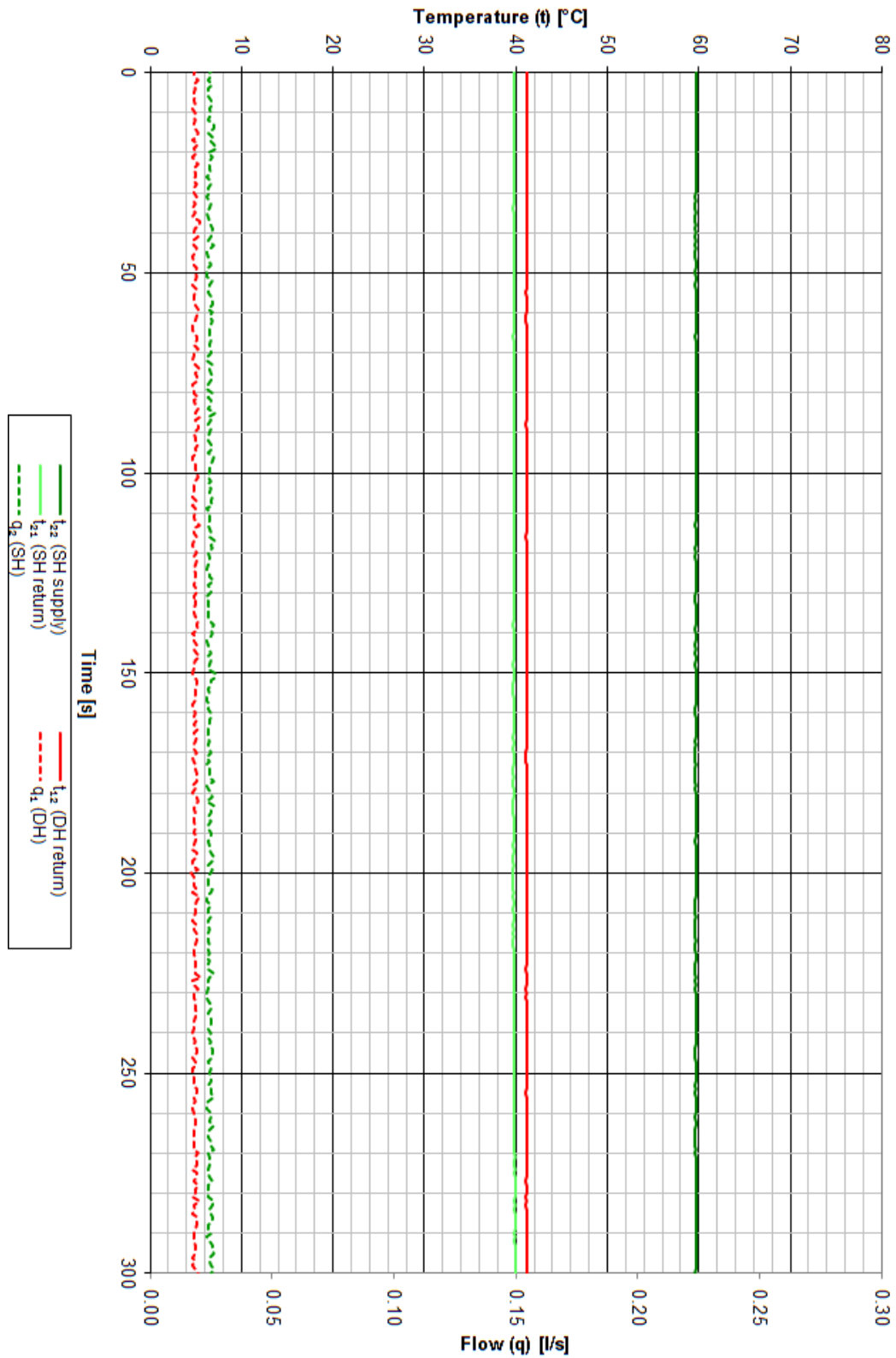

Appendix 2

Figure 5. Results for test point 1c: space heating 4 kW, DH 70 °C supply.

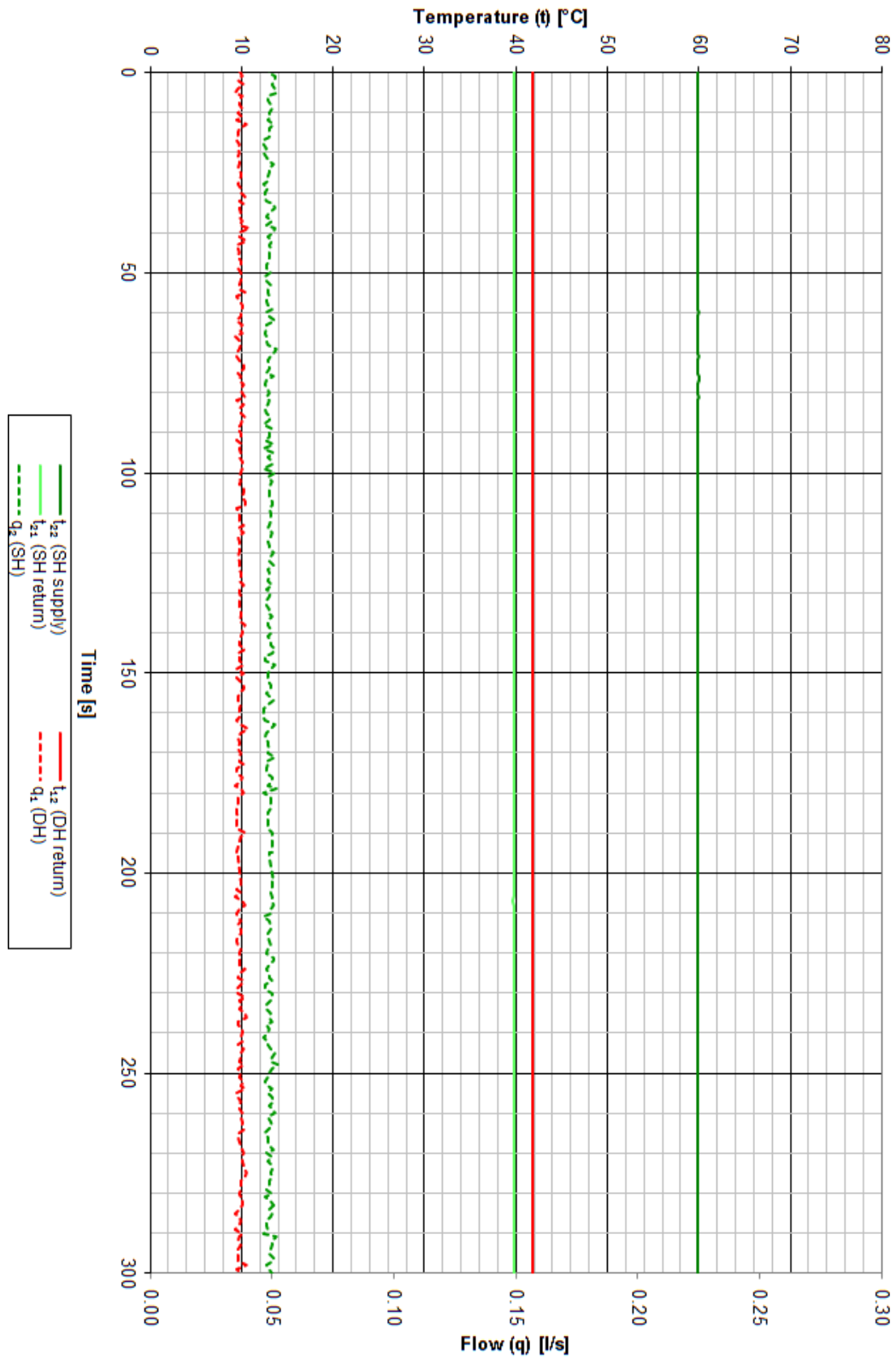

Appendix 2

Figure 6. Results for test point 2a: DHW only, DH 70 °C supply.

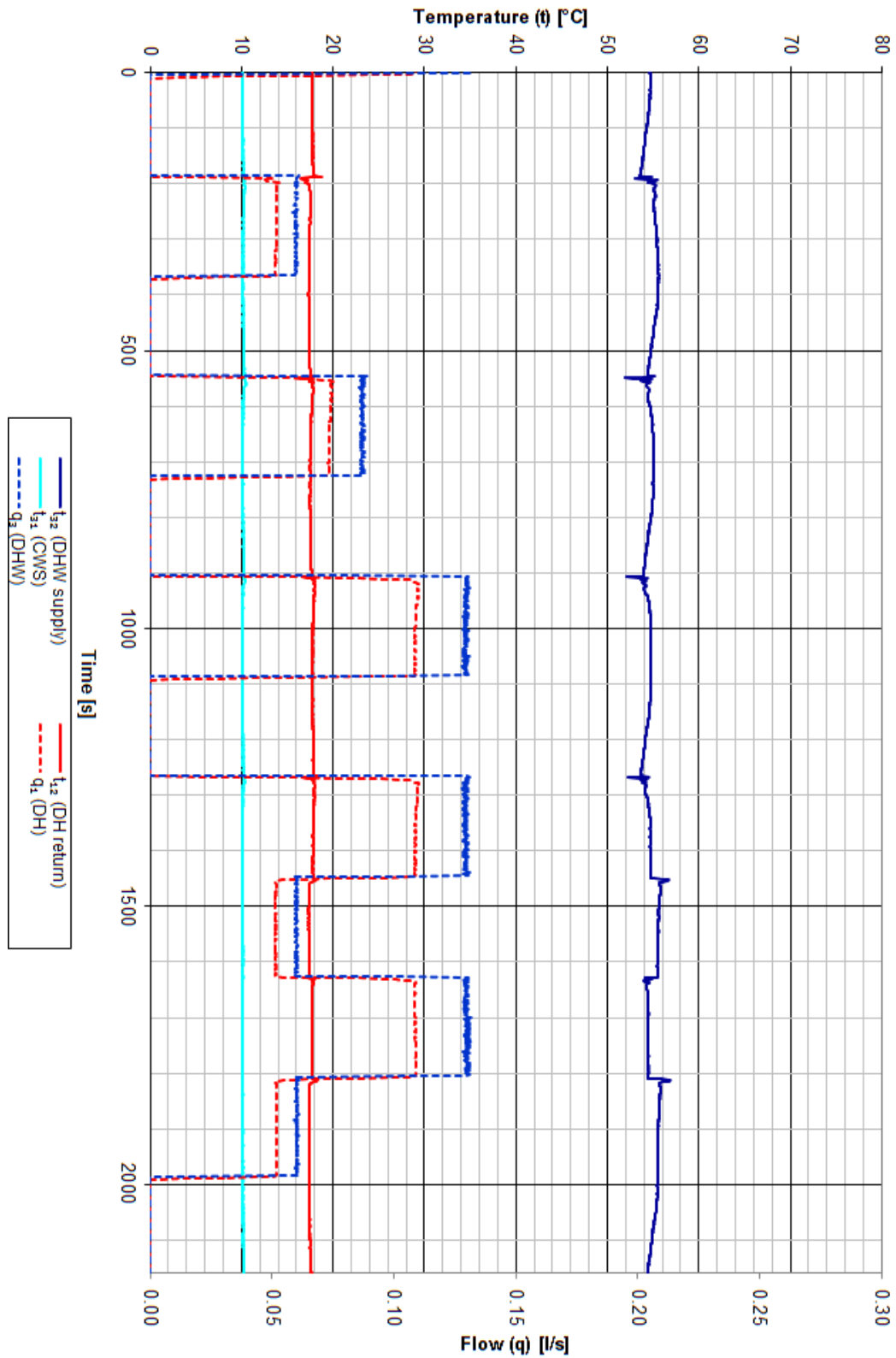

Appendix 2

Figure 7. Results for test point 3a: Low flow DHW, DH 70 °C supply.

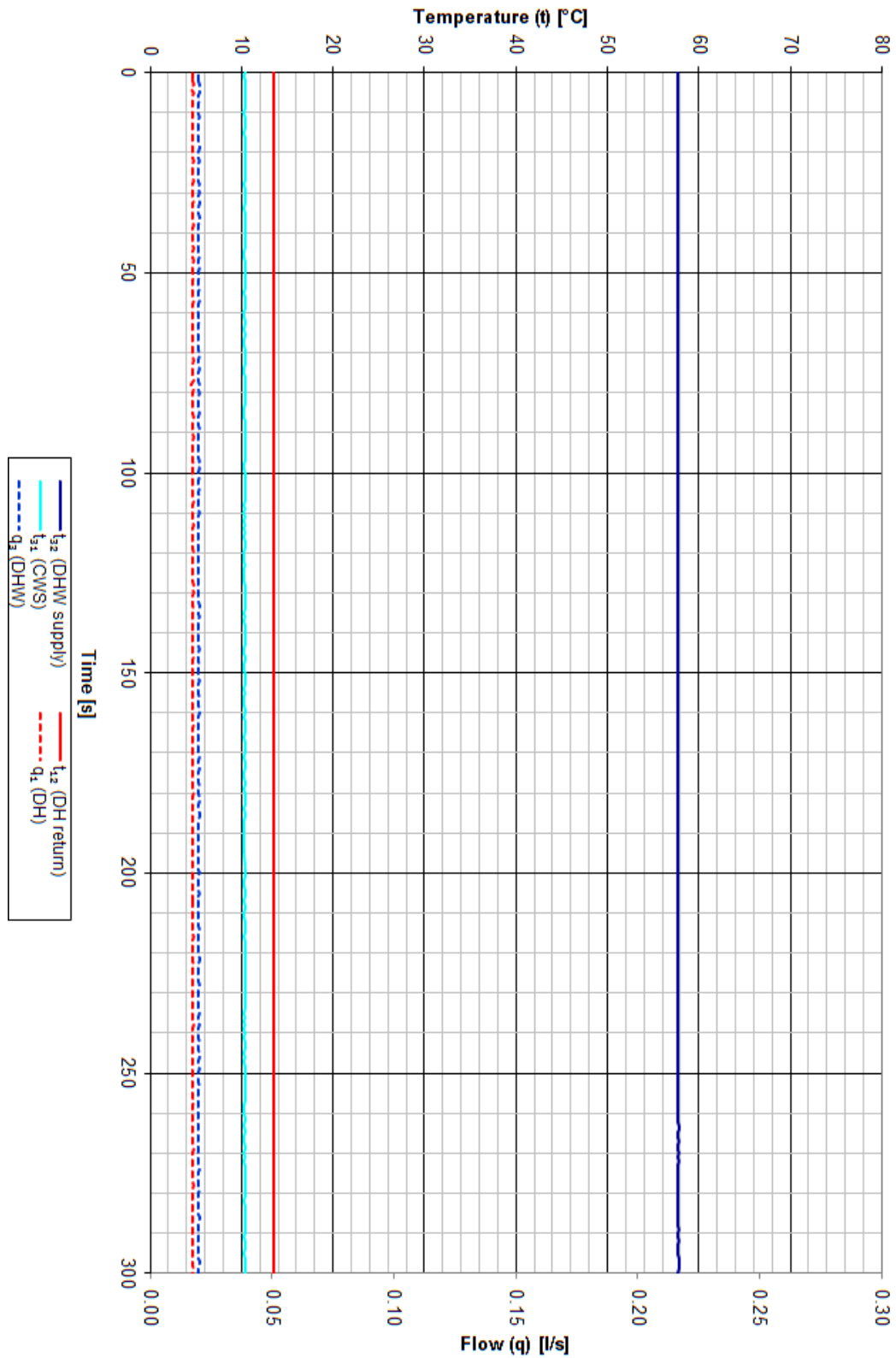

Appendix 2

Figure 8. Results for test point 4a: Keep-warm, DH 70 °C supply

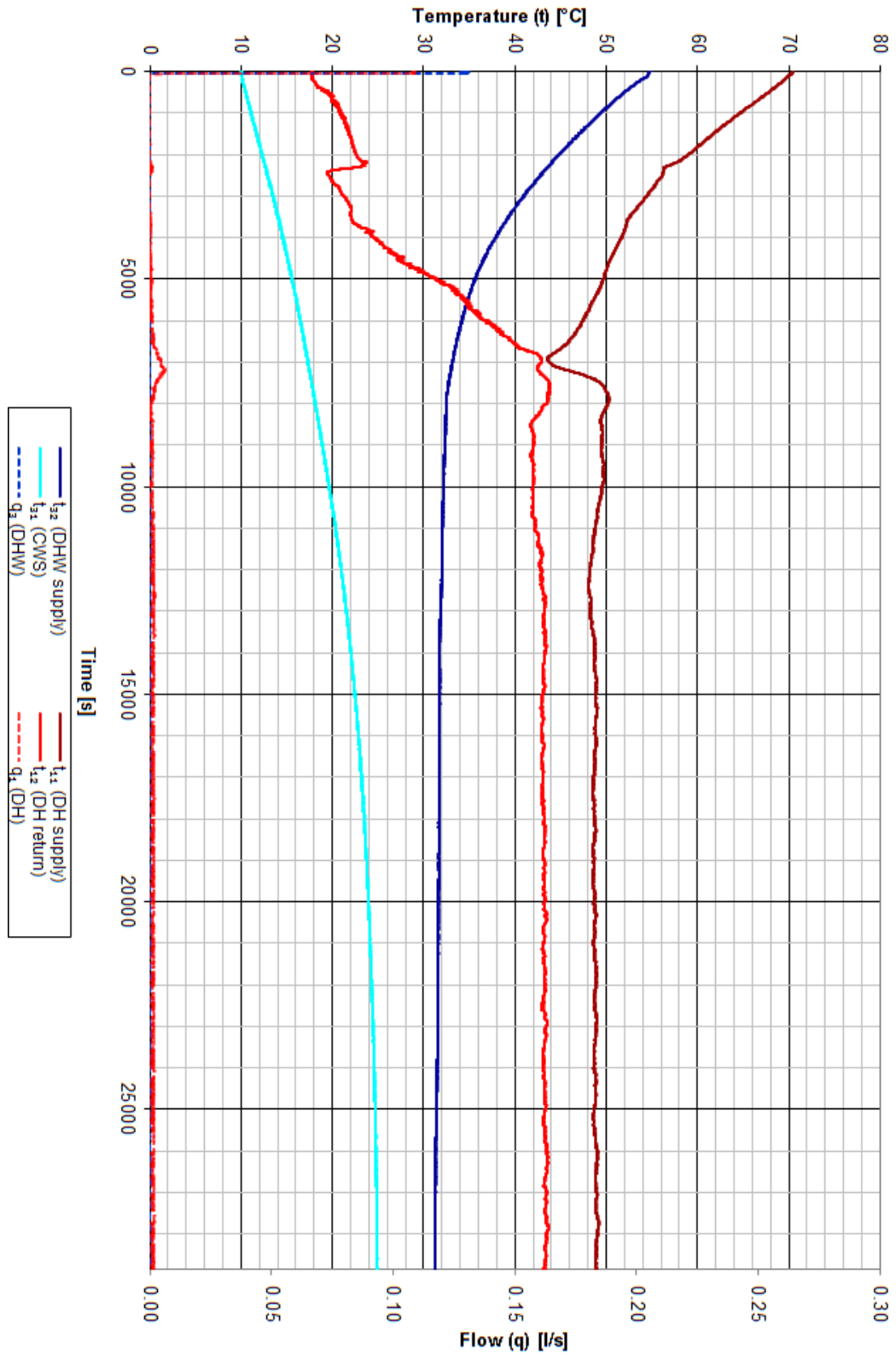

Appendix 2

Figure 9. Results for test point 5a: DHW response time, DH 70 °C supply.

