

Project Number: E4287

Project Title: BESA Test regime of T3 ECO HIU

Client: Switch2 Energy Ltd

Client Address: The Waterfront
Salt Mills Road
Shipley
West Yorkshire
BD17 7EZ

Date: 07 August 2019

Report Number: 1

Prepared By: 

I. Williamson / Project Engineer

Approval By: 

Howard Ruston / R&D Manager



This report is confidential to the client named on the front cover.

This report may be stored, transmitted or reproduced in full by the named client, however if the report is to be placed in the public domain or used for publicity / promotional purposes please inform a director of Enertek International Ltd.

The report must not be reproduced in part, edited, abridged or any extracts used for any purpose whatsoever without written permission from a director of Enertek International Ltd.

Any test results contained in this report apply only to the specific sample(s) tested as described in the report.

This report does not imply or indicate any element of commercial approval, recommendation or promotion by Enertek International Ltd.

CONTENTS

1	BRIEF	4
2	DEFINITIONS	5
3	TEST OBJECT	6
3.1	Appliance Details.....	6
3.2	Design Pressures	6
3.3	Design temperatures.....	6
4	TEST METHOD	7
4.1	Installation of Appliance	7
4.2	Test Regime.....	7
4.3	Measurement & Uncertainties	7
5	TEST RESULTS	12
5.1	Test 0 –Pressure Test	12
5.2	Test 1a to 1f – Space Heating 1-4 kW at 70 and 60 °C	12
5.3	Test 2a – DHW only at 70 °C	13
5.4	Test 2b – DHW only at 60 °C	13
5.5	Test 3c – Low Flow DHW at 70 °C	13
5.6	Test 3d – Low Flow DHW at 60 °C	13
5.7	Test 4a – Keep-warm at 70 °C	14
5.8	Test 4b – Keep-warm at 60 °C.....	14
5.9	Test 5a – DHW Response Time at 70 °C.....	15
5.10	Test 5b – DHW Response Time at 60 °C.....	15
5.11	Overall Scaling Risk Assessment.....	15
5.12	Test Summary	15
5.13	VWART Calculations	16
6	CONCLUSIONS	16
7	APPENDIX A	17
7.1	Key Metric Plots	17
7.2	Key Metric and VWART Summary	32
8	APPENDIX B	38
8.1	Appliance Documentation	38
8.2	Appliance Components	39
8.3	Appliance Photographs	40
8.4	Calibrations and uncertainties	42

LIST OF FIGURES

Figure 4.1 – EIL’s HIU Test Rig schematic	8
Figure 7.1 - Test 1a – Space Heating 1 kW at 70 °C	18
Figure 7.2 - Test 1b – Space Heating 2 kW at 70 °C	19
Figure 7.3 - Test 1c – Space Heating 4 kW at 70 °C	20
Figure 7.4 - Test 1d – Space Heating 1 kW at 70 °C	21
Figure 7.5 - Test 1e – Space Heating 2 kW at 60 °C	22
Figure 7.6 - Test 1f – Space Heating 4 kW at 60 °C	23
Figure 7.7 - Test 2a – DHW only at 70 °C	24
Figure 7.8 - Test 2b – DHW only at 60 °C	25
Figure 7.9 - Test 3c – Low Flow DHW at 70 °C	26
Figure 7.10 - Test 3d – Low Flow DHW at 60 °C	27
Figure 7.11 - Test 4a – Keep-warm at 70 °C	28
Figure 7.12 - Test 4b – Keep-warm at 60 °C	29
Figure 7.13 - Test 5a – DHW Response Time at 70 °C	30
Figure 7.14 - Test 5b – DHW Response Time at 60 °C	31
Figure 8.1 – Photograph of appliance with case off	40
Figure 8.2 – Photograph of appliance with case on	40
Figure 8-3 – Data Label	41

LIST OF TABLES

Table 3.1 – Appliance Details	6
Table 3.2 – Appliance Design Pressures	6
Table 3.3 – Appliance Design Temperatures	6
Table 4.1 – Setup of tests (extracted from BESA Test Regime)	9
Table 4.2 – Test Reporting, adapted from BESA Test Regime	10
Table 5.1 - Test Results for Space Heating Tests 1a to 1f	12
Table 5.2 - Overall Scaling Risk Assessment	15
Table 5.3 – High Temperature VWART Calculations	16
Table 5.4 – Low Temperature VWART Calculations	16
Table 7.1 - key metrics of Low Temperature Package	33
Table 7.2 - key metrics of High Temperature Package	34
Table 7.3 – Low Temperature VWART calculations	35
Table 7.4 – High Temperature VWART calculations	35
Table 8.1 – Documentation Supplied	38
Table 8.2 – Appliance Components details	39
Table 8.3 - EIL Equipment Calibration and Uncertainties	42

1 BRIEF

- 1.1.1** Enertek international Limited (EIL), were contracted to receive, install and commission a production sample, T3 ECO HIU on behalf of Switch2 Energy Ltd.
- 1.1.2** To carry out the work involved to evaluate the performance of Domestic Hot Water (DHW) and Space Heating (SH) in accordance with the BESA UK HIU Test regime Technical Specification, Rev-009 requirements, a publicly available online test regime. This is here-on referred to as the Test Regime throughout this document.
- 1.1.3** To provide a report detailing the tests carried out and generated results in accordance with the Test Regime criteria, including calculations for Volume Weighted Average Return Temperatures (VWART).

2 DEFINITIONS

2.1.1 The following definitions and abbreviations have been used within this report:

Symbol	Description	Unit
P_1	Power, Primary side	kW
P_2	Power, Space Heating side	kW
P_3	Power, Domestic Hot Water	kW
t_{11}	Temperature, Primary Side Supply Connection	°C
t_{12}	Temperature, Primary Side Return connection	°C
t_{21}	Temperature, Space Heating Side Return Connection	°C
t_{22}	Temperature, Space Heating System Supply Connection	°C
t_{31}	Temperature, Cold Water Supply	°C
t_{32}	Temperature, Domestic hot Water Output from HIU	°C
q_1	Volume Flow, Primary side	L/s
q_2	Volume Flow, Space heating side	L/s
q_3	Volume flow, Domestic hot water	L/s
Δp_1	Primary Pressure drop across entire HIU unit	kPa
Δp_2	Pressure Drop, Space heating system across HIU	kPa
Δp_3	Pressure Drop, Domestic Hot Water across HIU	kPa
$VWART_{DHW}$	DHW Volume Weighted Return Temperature	°C
$VWART_{SH}$	Space Heating Volume Weighted Return Temperature	°C
$VWART_{KWH}$	Keep Warm Volume Weighted Return Temperature	°C
$VWART_{HEAT}$	Annual Volume Weighted Return Temperature for Heating Period	°C
$VWART_{NONHEAT}$	Annual Volume Weighed Return Temperature for Non-Heating	°C
$VWART_{HIU}$	Total Annual Volume Weighted Return Temperature	°C
DHW	Domestic Hot Water	—
HIU	Heat Interface Unit	—
SH	Space Heating	—
TMV	Thermostatic mixing Valve	—

3 TEST OBJECT

3.1 Appliance Details

3.1.1 Details of the HIU T3 ECO HIU appliance are given in Table 3.1. Photograph of the installed appliance is given in Figure 8.1.

3.2 Design Pressures

3.2.1 The maximum design pressures of the T3 ECO HIU appliance are given for the primary side and the secondary side for both Space Heating and DHW in Table 3.2.

3.3 Design temperatures

3.3.1 The maximum design temperatures of the T3 ECO HIU appliance are given for the primary side and the secondary side for both Space Heating and DHW in Table 3.3

Table 3.1 – Appliance Details

Item	Description
Manufacturer	Switch2 Energy Ltd
Model	T3 ECO HIU
Serial number	S2HIU19000576
Year of manufacture	2019
DHW priority	Yes

Table 3.2 – Appliance Design Pressures

Item	Value	Unit
Primary Side	16	Bar
Secondary Side space Heating	3	Bar
Secondary Side DHW	10	Bar

Table 3.3 – Appliance Design Temperatures

Item	Value	Unit
Primary Side	90	°C
Secondary Side space Heating	80	°C
Secondary Side DHW	65	°C

4 TEST METHOD

4.1 Installation of Appliance

4.1.1 The appliance was installed and commissioned (as received) and as defined in the product literature provided. Testing was carried out without further adjustment other than disabling the internal space heating pump and adjusting the setting of the SH and DHW set points through the user interface on the HIU controller to suit the conditions of the HIU test rig. The HIU rig schematic is given in Figure 4.1.

4.2 Test Regime

4.2.1 The testing described in this report was carried out in accordance with the BESA test regime¹. The Test Regime outlines a series of static and dynamic tests to determine the performance of a HIU's DHW and SH functions. The Regime outlines the test method including the reporting of the results, the performance requirements and the VVART calculations.

4.2.2 The setup of the BESA tests is reproduced in Table 4.1. The basis of reporting the performance of the HIU from the BESA Test Regime is reproduced in Table 4.2.

4.2.3 The Test Regime specifies the testing of two different test temperature packages. The first is the high temperature package, with a district primary supply of 70 °C and the second is the 'low temperature' package, with a district primary supply temperature of 60 °C.

4.2.4 As the Switch2 Energy Ltd, T3 ECO HIU is suitable for both high and low temperature operation, both test packages were carried out and results recorded within this report.

4.3 Measurement & Uncertainties

4.3.1 All measurements and uncertainties adhere to the requirements stipulated in the BESA Test Regime. All measurements were sampled at a rate of 1 Hz for all tests.

4.3.2 The BESA uncertainties of measurement requirements are as follows: Differential Pressure, ± 1 kPa; Temperature, ± 0.1 °C; Volume Flow, ± 1.5 %. Note: the time constant for the temperature sensors is less than 1.5 s.

4.3.3 EIL's reported uncertainty is based on a standard uncertainty by a coverage factor $K=2$, providing a level of confidence of approximately 95%. The uncertainty evaluation has been carried out in accordance with UKAS requirements. The EIL equipment list and uncertainties are given in Table 8.3, Appendix B.

¹ UK HIU Test Regime Technical Specification, Rev-009 requirements, issued by the Building Engineering Services Association (BESA)

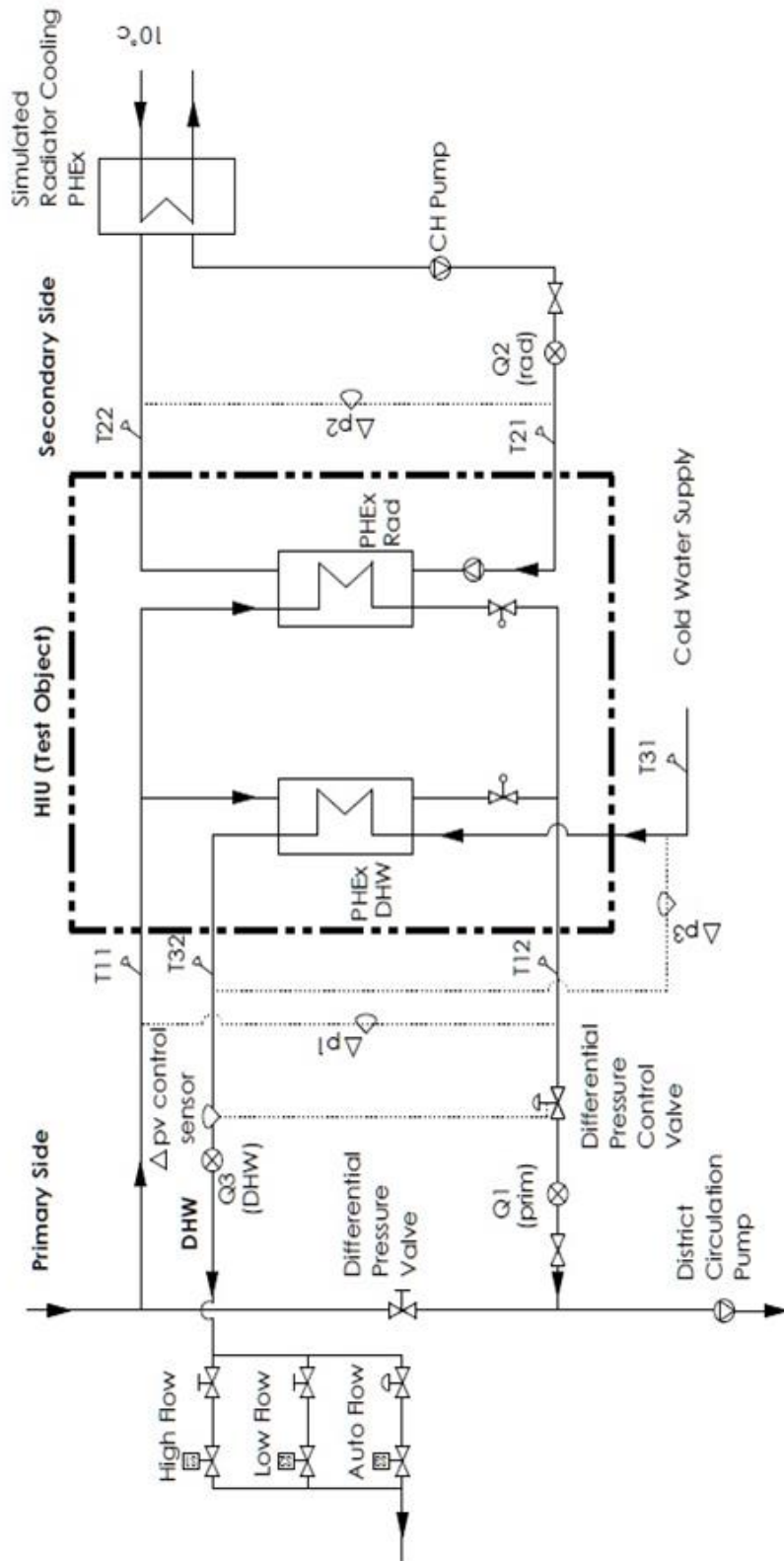

Figure 4.1 – EIL’s HIU Test Rig schematic

Table 4.1 – Setup of tests (extracted from BESA Test Regime)

No	Test	static pressure on return	dP across HIU	Primary flow temp	DHW setpoint	DHW flow rate	DHW power	SH output	SH flow temp	SH return temp
		bar	bar	°C	°C	l/s	kW	kW	°C	°C
			dP_1	t_{11}	t_{32}	q_3	P_3	P_2	t_{22}	t_{21}
Static tests										
0a	Static pressure test (same static pressure on both flow and return connections)	1.43 times rated value	1.43 times rated value	n/a	n/a	n/a	n/a	n/a	n/a	n/a
1a	Space Heating 1 kW (DH 70 °C flow)	2.5	0.5	70	55	0	0	1	60	40
1b	Space Heating 2 kW (DH 70 °C flow)	2.5	0.5	70	55	0	0	2	60	40
1c	Space Heating 4 kW (DH 70 °C flow)	2.5	0.5	70	55	0	0	4	60	40
1d	Space Heating 1 kW (DH 60 °C flow)	2.5	0.5	60	50	0	0	1	45	35
1e	Space Heating 2 kW (DH 60 °C flow)	2.5	0.5	60	50	0	0	2	45	35
1f	Space Heating 4 kW (DH 60 °C flow)	2.5	0.5	60	50	0	0	2	45	35
Dynamic tests										
2a	DHW only (DH 70 °C flow)	2.5	0.5	70	55	DHW test profile	DHW test profile	0	n/a	n/a
2b	DHW only (DH 60 °C flow)	2.5	0.5	60	50	DHW test profile	DHW test profile	0	n/a	n/a
3a	Low flow DHW (DH 70 °C flow)	2.5	0.5	70	55	0.02	Record value	0	n/a	n/a
3b	Low flow DHW (DH 60 °C flow)	2.5	0.5	60	50	0.02	Record value	0	n/a	n/a
4a	Keep-warm (DH 70 °C flow)	2.5	0.5	70	55	0	0	0	n/a	n/a
4b	Keep-warm (DH 60 °C flow)	2.5	0.5	60	50	0	0	0	n/a	n/a
5a	DHW response time (DH 70 °C flow)	2.5	0.5	70	55	0.13	Record value	0	n/a	n/a
5b	DHW response time (DH 60 °C flow)	2.5	0.5	60	50	0.13	Record value	0	n/a	n/a

Table 4.2 – Test Reporting, adapted from BESA Test Regime

Test	Description	Reporting
Static Tests		
0	Pressure Tests.	Pass/Fail as to whether HIU manages pressure test without leaks or damage.
1a	Space heating 1 kW, 60/40 °C secondary.	t_{11} – Primary flow temperature. t_{12} – Primary return temperature. Plot of key metrics over duration of test. Note: Outputs used as input data to ‘High Temperature’ Space Heating Volume Weighted Average Return Temperature calculation.
1b	Space heating 2 kW, 60/40 °C secondary.	
1c	Space heating 4 kW, 60/40 °C secondary.	
1d	Space heating 1 kW, 45/35 °C secondary.	
1e	Space heating 2 kW, 45/35 °C secondary.	t_{11} – Primary flow temperature. t_{12} – Primary return temperature. Plot of key metrics over duration of test. Note: Outputs used as input data to ‘Low Temperature’ Space Heating Volume Weighted Average Return Temperature calculation.
1f	Space heating 4 kW, 45/35 °C secondary.	
Dynamic Tests		
2a	DHW only, DH 70 °C flow; 55 °C DHW.	Pass/Fail on DHW (at t_{32}) exceeding 65.0 °C (to 1 decimal point) for more than 10 consecutive seconds. ‘State the maximum and minimum DHW temperatures over the period of the test when there is a DHW flow. Assessment of scaling risk as per the criteria detailed in 2.26. Note: Outputs used as input data to ‘High Temperature’ Space Heating Volume Weighted Average Return Temperature calculation. Plot t_{32} , t_{31} , q_3 , t_{12} , q_1
2b	DHW only, DH 60 °C flow; 50 °C DHW.	State the maximum and minimum DHW temperatures over the period of the test when there is a DHW flow. Plot q_1 , q_3 , dp_1 , dp_3 Note: Outputs used as input data to ‘Low Temperature’ Domestic Hot Water Volume Weighted Average Return Temperature calculation.
3c	Low flow DHW, DH 70 °C flow; 55 °C DHW.	Pass/Fail on DHW (at t_{32}) exceeding 65.0 °C (1 decimal place) for more than 10 consecutive seconds. Comment on ability to deliver DHW at low flow based on DHW temperature reaching at least 45.0 °C (1 decimal place) at the end of the 180 second period of low flow DHW. Comment on the ability to deliver stable DHW flow temperature (at t_{32}), defined as ability to maintain 55.0 +/- 3.0 °C (1 decimal place) during the last 60 seconds of the test. Maximum temperature achieved and +/- °C variance around 55.0 °C (1 decimal place) to be stated. Assessment of scaling risk as per criteria detailed in 2.26. Plot of key metrics for 60 seconds of 0.13 l/s flow and the subsequent 180 seconds of 0.02 l/s DHW flow.
3d	Low flow DHW, DH 60 °C flow; 50 °C DHW.	Comment on the ability to deliver DHW at low flow rate based on DHW temperature reaching at least 45 °C (1 decimal place) at the end of the 180 second period of low flow DHW. Comment on the ability to deliver stable DHW flow temperature (at t_{32}), defined as ability to maintain 50.0 +/- 3 °C (1 decimal place) to be stated. Plot of key metrics for 60 seconds of 0.13 l/s flow and the subsequent 180 seconds of 0.02 l/s DHW flow. Maximum temperature achieved and +/- °C variance around 50.0 °C (1 decimal place) to be stated.
4a	Keep-warm, DH 70 °C flow; 55 °C DHW.	Assessment of whether valid keep-warm operation, based on 5a response time criteria: Pass/Fail. Plot temperature t_{10}

		<p>Assessment of scaling risk, based on duration of temperatures in excess of 55.0 °C (1 decimal place).</p> <p>Comment on HIU keep-warm controls options.</p> <p>Plot of key metrics over duration of test.</p> <p>State average heat load for the duration of the test.</p> <p>State the average primary flow rate for the duration of the test.</p> <p>Note: Outputs used as input data to 'High Temperature' Keep-warm Volume Weighted Average Return Temperature calculation.</p>
4b	Keep-warm, DH 60 °C flow; 50 °C DHW.	<p>Assessment of whether valid keep-warm operation, based on 5a response time criteria: Pass/Fail.</p> <p>Observation on the operation of the HIU during keep-warm.</p> <p>Assessment of scaling risk based on extent and duration of temperatures in excess of 55.0 °C (1 decimal place).</p> <p>Comment on HIU keep-warm controls options.</p> <p>Plot of key metrics over duration of test.</p> <p>State average heat load for the duration of the test.</p> <p>State the average primary flowrate for the duration of the test.</p> <p>Note: Outputs used as input data to 'Low Temperature' Keep-warm Volume Weighted Average Return Temperature calculation.</p>
5a	DHW response time, DH 70 °C flow; 55 °C DHW.	<p>Pass/Fail on DHW (at t_{32}) exceeding 65.0 °C (1 decimal place) for more than 10 consecutive seconds.</p> <p>State time to achieve 45.0 °C (1 decimal place) and not subsequently drop below 42.0 °C (1 decimal place).</p> <p>Plot t_{32}, t_{31}, t_{12}, q_1</p>
5b	DHW response time, DH 60 °C flow; 50 °C DHW.	<p>State time to achieve a DHW temperature 45.0 °C (1 decimal place) and not subsequently drop below 42.0 °C (1 decimal place).</p> <p>Comment on stability of DHW temperature.</p> <p>Plot t_{32}, t_{31}, t_{12}, q_1 over duration of test.</p>

5 TEST RESULTS

5.1 Test 0 –Pressure Test

5.1.1 The appliance has passed the requirements of the static pressure test, Test 0 of the BESA Test Regime as:

5.1.2 There was No damage observed during the static pressure test, with the primary flow pressurised to 22.88 bar (1.43 times the rated value), and;

5.1.3 There were No leaks observed during the static pressure test, with the primary flow pressurised to 22.88 bar (1.43 times the rated value).

5.2 Test 1a to 1f – Space Heating 1-4 kW at 70 and 60 °C

5.2.1 The plot of the key metrics of Tests 1a-1f for the space heating 1 - 4 kW at both 70 and 60 °C are displayed in Figure 7.1 to Figure 7.6 respectively. See Table 5.1 for summarised test results including the average primary return temperature, t_{12} .

Table 5.1 - Test Results for Space Heating Tests 1a to 1f

Test	Description	Primary					Secondary				
		t_{11} °C	t_{12} °C	q_1 l/s	Δp_1 kPa	P_1 W	t_{21} °C	t_{22} °C	q_2 l/s	Δp_2 kPa	P_2 W
1a	- 1 kW Space Heating (DH 70 °C flow)	70.0	38.2	0.010	49.4	1353	40.0	60.3	0.013	-0.3	1079
1b	- 2 kW Space Heating (DH 70 °C flow)	70.3	39.8	0.017	51.1	2211	39.9	59.8	0.013	0.2	2011
1c	- 4 kW Space Heating (DH 70 °C flow)	69.7	40.8	0.034	51.2	4110	40.2	60.2	0.047	1.8	3900
1d	- Space Heating 1 kW (DH 60 °C flow)	59.9	34.4	0.011	51.7	1207	35.1	45.9	0.024	0.2	1070
1e	- Space Heating 2 kW (DH 60 °C flow)	60.1	34.5	0.021	51.9	2260	35.1	45.5	0.024	1.8	2059
1f	- Space Heating 4 kW (DH 60 °C flow)	59.6	34.2	0.041	51.9	4319	34.8	44.9	0.094	8.5	4020

5.3 Test 2a – DHW only at 70 °C

- 5.3.1** The appliance has passed the requirements of the DHW only at 70 °C, Test 2a of the BESA Test Regime as:
- 5.3.2** The domestic hot water output temperature, t_{32} did not exceed 65 °C for more than 10 seconds.
- 5.3.3** The maximum and minimum temperatures of t_{32} were 56.7°C and 47.5°C respectively.
- 5.3.4** The plot of the key metrics of the duration of Test 2a is displayed in Figure 7.7, Appendix.

5.4 Test 2b – DHW only at 60 °C

- 5.4.1** The maximum and minimum temperatures of t_{32} were 51.5°C and 45.9°C respectively.
- 5.4.2** The plot of the key metrics of the duration of Test 2b is displayed in Figure 7.8, Appendix.

5.5 Test 3c – Low Flow DHW at 70 °C

- 5.5.1** The appliance has passed the requirements of the Low Flow at 70 °C, Test 3c of the BESA Test Regime as:
- 5.5.2** The declared low flow rate by the manufacturer was 0.033 l/s.
- 5.5.3** The domestic hot water output temperature, t_{32} did not exceed 65 °C for more than 10 seconds, and;
- 5.5.4** The appliance did maintain the DHW output temperature, t_{32} at 55 ± 3 °C during the last 60 seconds of the test.
- 5.5.5** The maximum and minimum temperatures of t_{32} were 58.67°C and 50.94°C respectively.
- 5.5.6** The plot of the key metrics of the duration of Test 3c is displayed in Figure 7.9, Appendix.

5.6 Test 3d – Low Flow DHW at 60 °C

- 5.6.1** The appliance did maintain the DHW output temperature, t_{32} at 50 ± 3 °C during the last 60 seconds of the test.
- 5.6.2** The declared low flow by the manufacturer was 0.033 l/s.
- 5.6.3** The maximum and minimum temperatures of t_{32} were 53.59°C and 46.41°C respectively.
- 5.6.4** The plot of the key metrics of the duration of Test 3d is displayed in Figure 7.10, Appendix.

5.7 Test 4a – Keep-warm at 70 °C

- 5.7.1 The appliance has passed the requirements of the Keep-warm at 70 °C, Test 4a of the BESA Test Regime as:
- 5.7.2 This is a valid keep warm operation based on 5a response time criteria, see 5.9.3.
- 5.7.3 The appliance is not performing keep-warm cycling as the primary flow temperature, t_{11} does not vary by more than ± 3 °C during the final 3 hours of the test.
- 5.7.4 The appliance is not performing keep-warm function as no cycling was observed.
- 5.7.5 The DHW output temperature t_{32} was in excess of 55 °C for a total of 0 seconds throughout the duration of the test.
- 5.7.6 The average heat load on the primary side P_1 is 86.3 W.
- 5.7.7 The average primary flow q_1 over the 8 hour test was 10.155 l/hr.
- 5.7.8 The Keepwarm control was set to 45°C .
- 5.7.9 The plot of the key metrics of the duration of Test 4a is displayed in Figure 7.11, Appendix.

5.8 Test 4b – Keep-warm at 60 °C

- 5.8.1 The appliance has passed the requirements of the Keep-warm at 60 °C, Test 4b of the BESA Test Regime as:
- 5.8.2 This is a valid keep warm operation based on 5b response time criteria, see 5.10.1.
- 5.8.3 The appliance is not performing keep-warm cycling as the primary flow temperature, t_{11} does not vary by more than ± 3 °C during the final 3 hours of the test.
- 5.8.4 The appliance is not performing keep-warm function as no cycling was observed.
- 5.8.5 The DHW output temperature t_{32} was in excess of 55 °C for a total of 0 seconds throughout the duration of the test.
- 5.8.6 The average heat load on the primary side P_1 is 70.2 W.
- 5.8.7 The average primary flow q_1 over the 8 hour test was 9.363 l/hr.
- 5.8.8 The plot of the key metrics of the duration of Test 4b is displayed in Figure 7.12, Appendix.

5.9 Test 5a – DHW Response Time at 70 °C

- 5.9.1** The appliance has passed the requirements of DHW Response Time at 70°C, Test 5a of the BESA Test Regime as:
- 5.9.2** The domestic hot water output temperature t_{32} did not exceed 65 °C for more than 10 seconds.
- 5.9.3** The DHW response time for t_{32} to reach 45 °C (and not subsequently drop below 42 °C) was 6 seconds; therefore this is a valid keep warm.
- 5.9.4** The plot of the key metrics of the duration of Test 5a is displayed in Figure 7.13, Appendix.

5.10 Test 5b – DHW Response Time at 60 °C

- 5.10.1** The DHW response time for t_{32} to reach 45 °C (and not subsequently drop below 42 °C) was 8 seconds; therefore this is a valid keep warm.
- 5.10.2** The plot of the key metrics of the duration of Test 5b is displayed in Figure 7.14, Appendix.

5.11 Overall Scaling Risk Assessment

- 5.11.1** If any of the below factors occur then the risk of scaling of the DHW plate in hard water areas increases.

Table 5.2 - Overall Scaling Risk Assessment

<i>HIU has a TMV or TRV on the output of the DHW plate heat exchanger.</i>	No	
Test Designation	2a	3c
<i>t_{32} above 60 °C for more than 5 seconds</i>	No	No
<i>t_{12} exceeds 55 °C at any point of the test</i>	No	No
Test Designation	4a	4b
<i>t_{12} exceeds 50 °C at any time</i>	Yes	-

5.12 Test Summary

- 5.12.1** See Table 7.1 and Table 7.2, Appendix for the summary of key metrics of all the tests described in this report.

5.13 VWART Calculations

5.13.1 The Volume Weighted Average Return Temperature (VWART) has been calculated as stipulated in the BESA UK HIU Test Regime document. The calculated VWART values for both the high temperature and low temperature tests described in this report are given below in Table 5.3 and Table 5.4 respectively.

Table 5.3 – High Temperature VWART Calculations

Symbol	Description	Value
SH _{PROP}	Annual Heating Period percentage	7 %
NSH _{PROP}	Annual Non-Heating Period percentage	93 %
VWART _{SH}	Space Heating Volume Weighted Return Temperature	40 °C
VWART _{DHW}	DHW Volume Weighted Return Temperature	16 °C
VWART _{KWM}	Keep Warm Volume Weight return Temperature	51 °C
VWART _{HEAT}	Annual Volume Weighted Return Temperature For Heating Period	41 °C
VWART _{NONHEAT}	Annual Volume Weighted Return Temperature For Non Heating	44 °C
VWART _{HIU}	Total Annual Volume Weighted Return Temperature	44 °C

Table 5.4 – Low Temperature VWART Calculations

Symbol	Description	Value
SH _{PROP}	Annual Heating Period percentage	7 %
NSH _{PROP}	Annual Non-Heating Period percentage	93 %
VWART _{SH}	Space Heating Volume Weighted Return Temperature	34 °C
VWART _{DHW}	DHW Volume Weighted Return Temperature	18 °C
VWART _{KWM}	Keep Warm Volume Weight return Temperature	43 °C
VWART _{HEAT}	Annual Volume Weighted Return Temperature For Heating Period	35 °C
VWART _{NONHEAT}	Annual Volume Weighted Return Temperature For Non Heating	37 °C
VWART _{HIU}	Total Annual Volume Weighted Return Temperature	37 °C

6 CONCLUSIONS

6.1.1 The low flow tests (3c and 3d) were conducted at 0.33 l/. This above the 0.02 l/s in the BESA regime.

6.1.2 The appliance has satisfied the performance requirements of the BESA HIU Test Regime.

All conclusions, opinions and interpretations indicated in this report are outside the scope of Enertek's UKAS accreditation.

7 APPENDIX A

7.1 Key Metric Plots

7.1.1 The graphical plots of the key metrics of the tests described in this report are given in this section.

GRAPHICAL PLOTS START ON NEXT PAGE

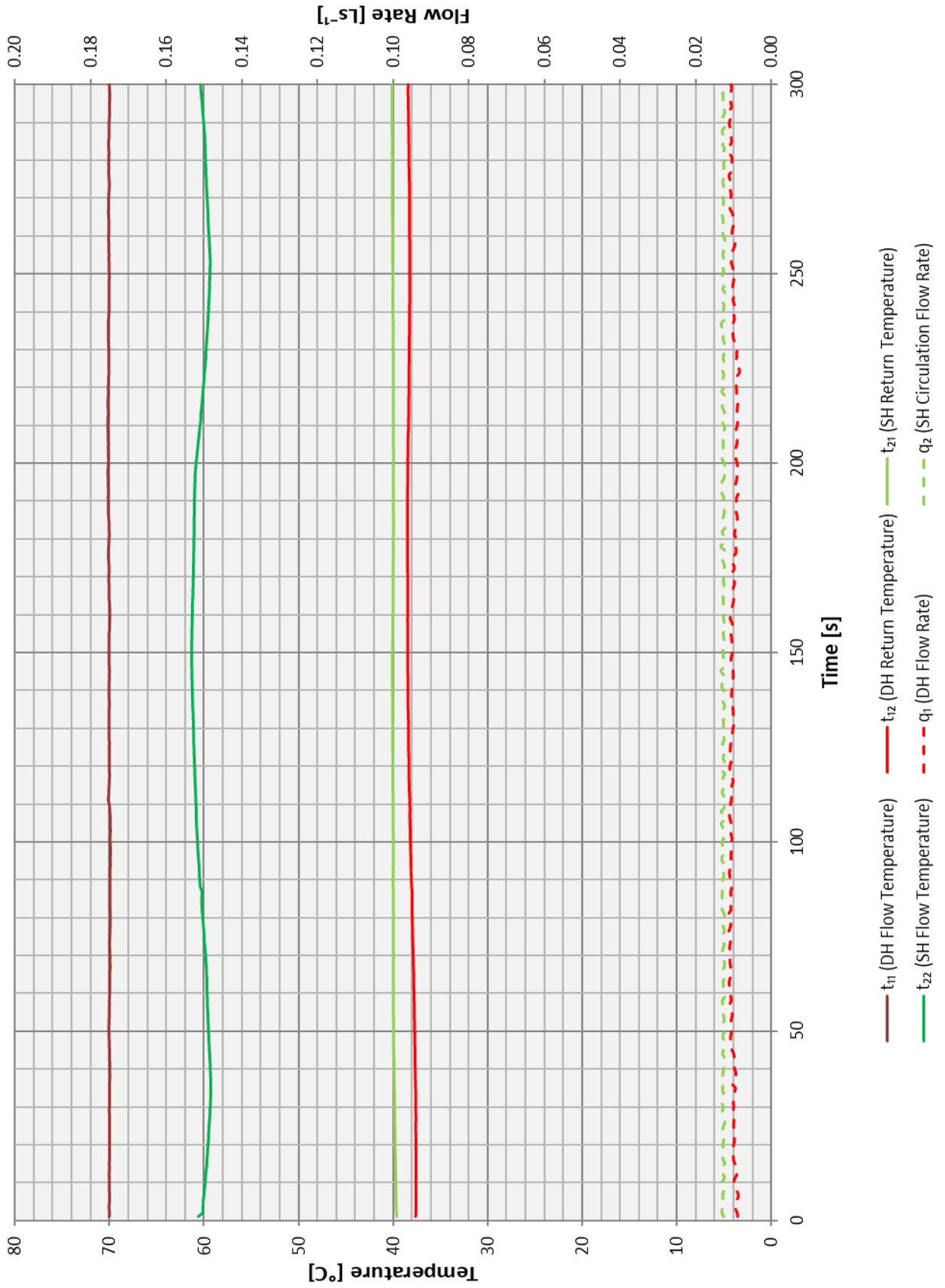

Figure 7.1 - Test 1a – Space Heating 1 kW at 70 °C

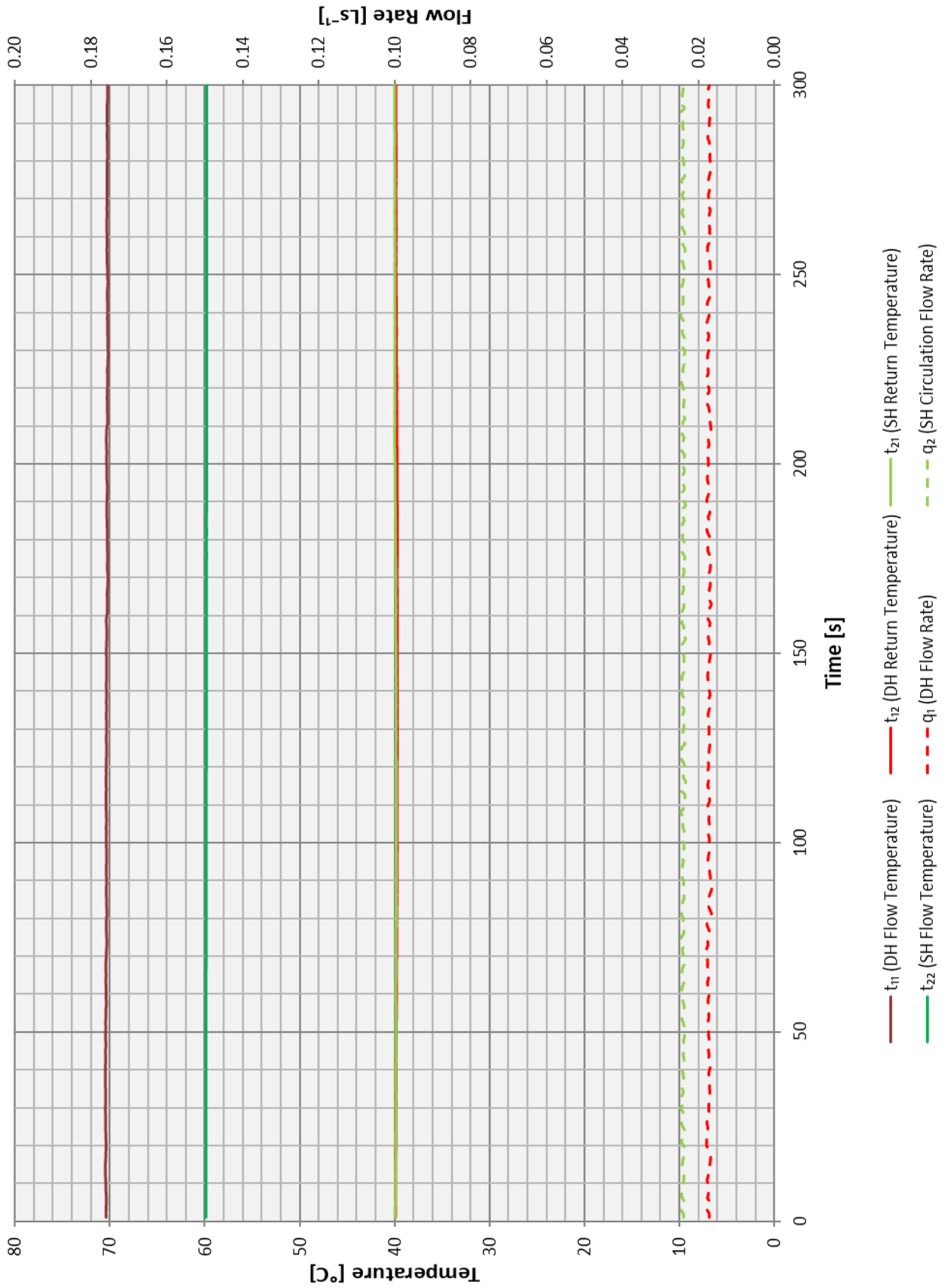

Figure 7.2 - Test 1b – Space Heating 2 kW at 70 °C

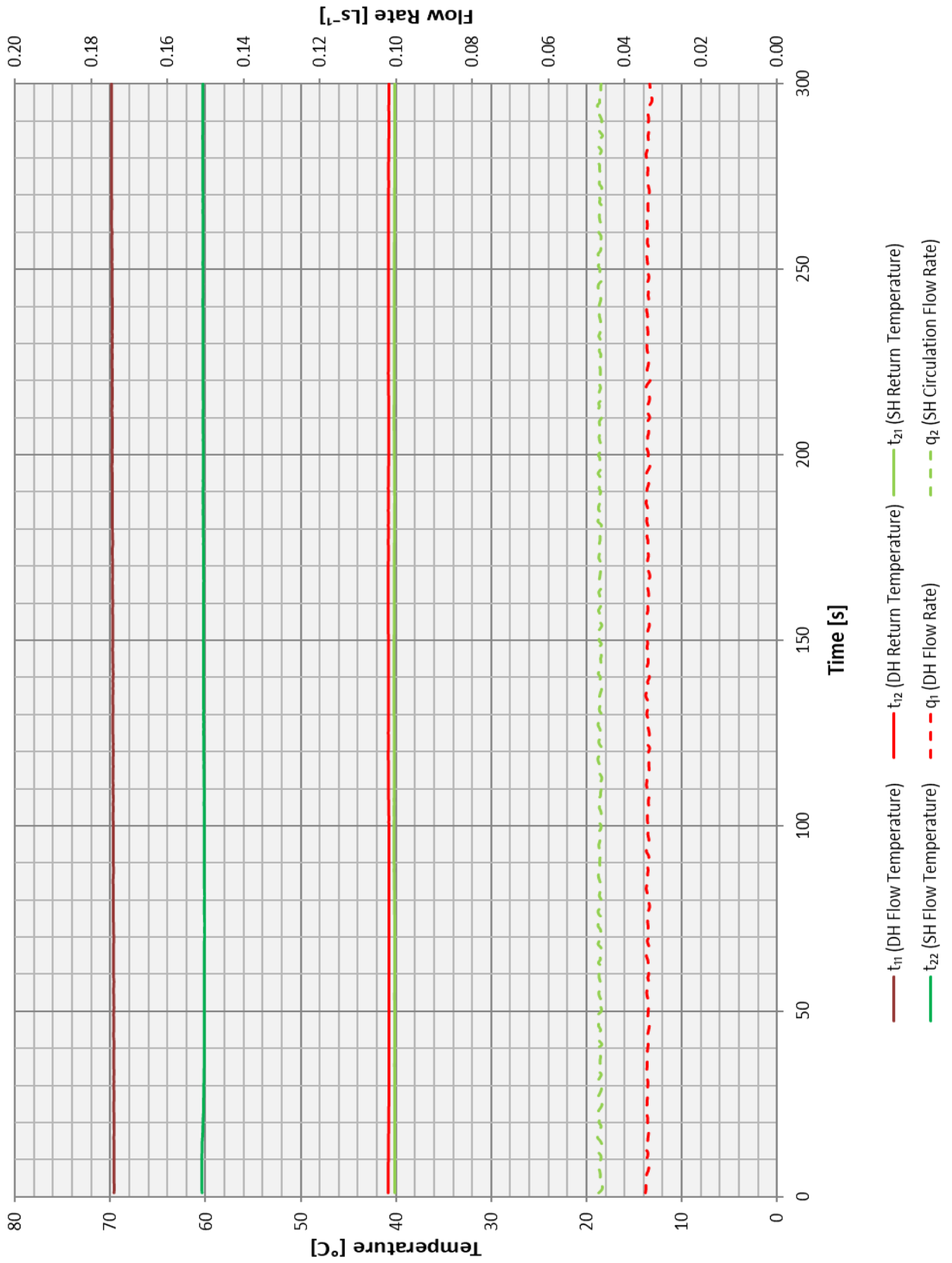

Figure 7.3 - Test 1c – Space Heating 4 kW at 70 °C

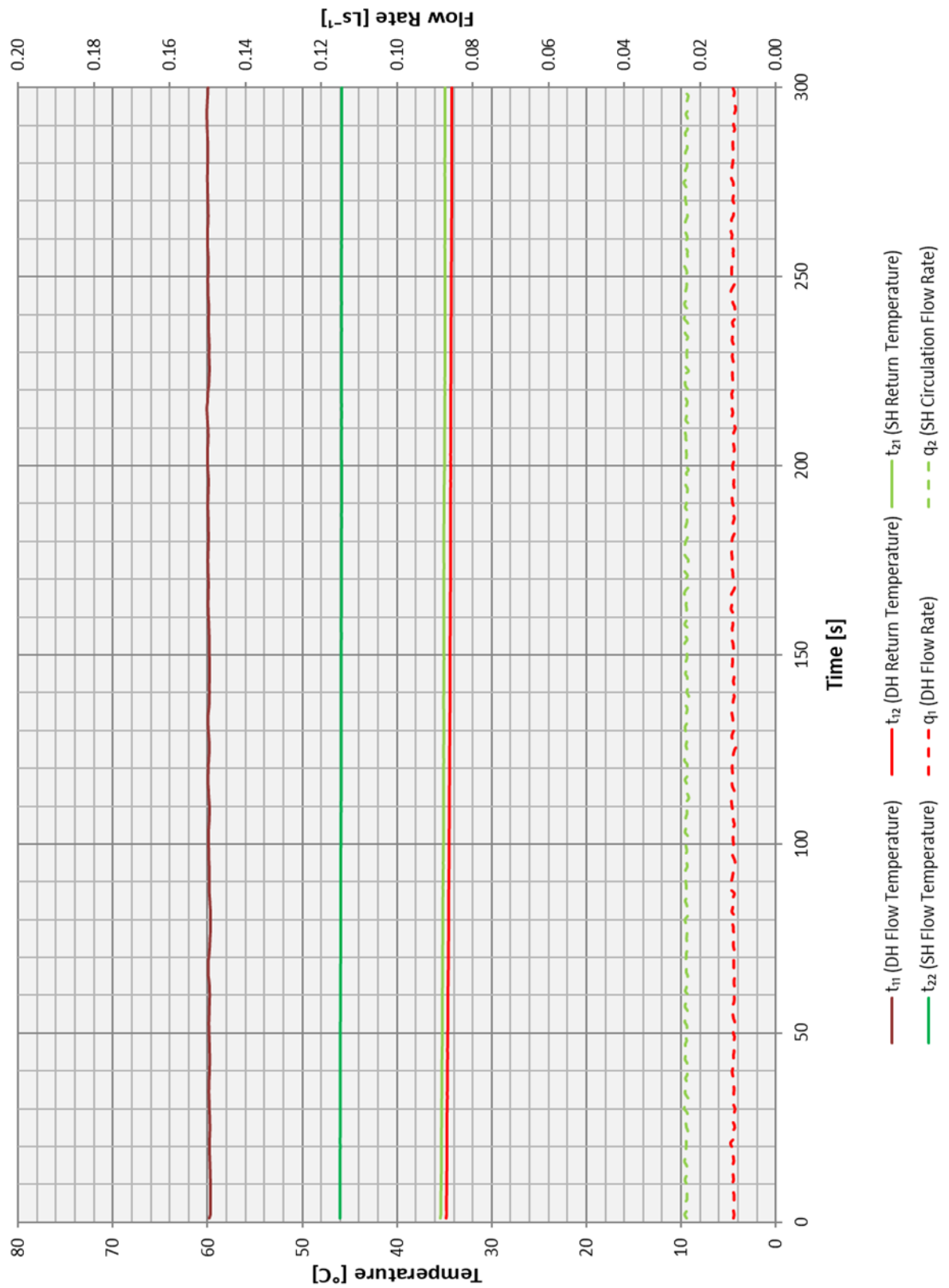

Figure 7.4 - Test 1d – Space Heating 1 kW at 70 °C

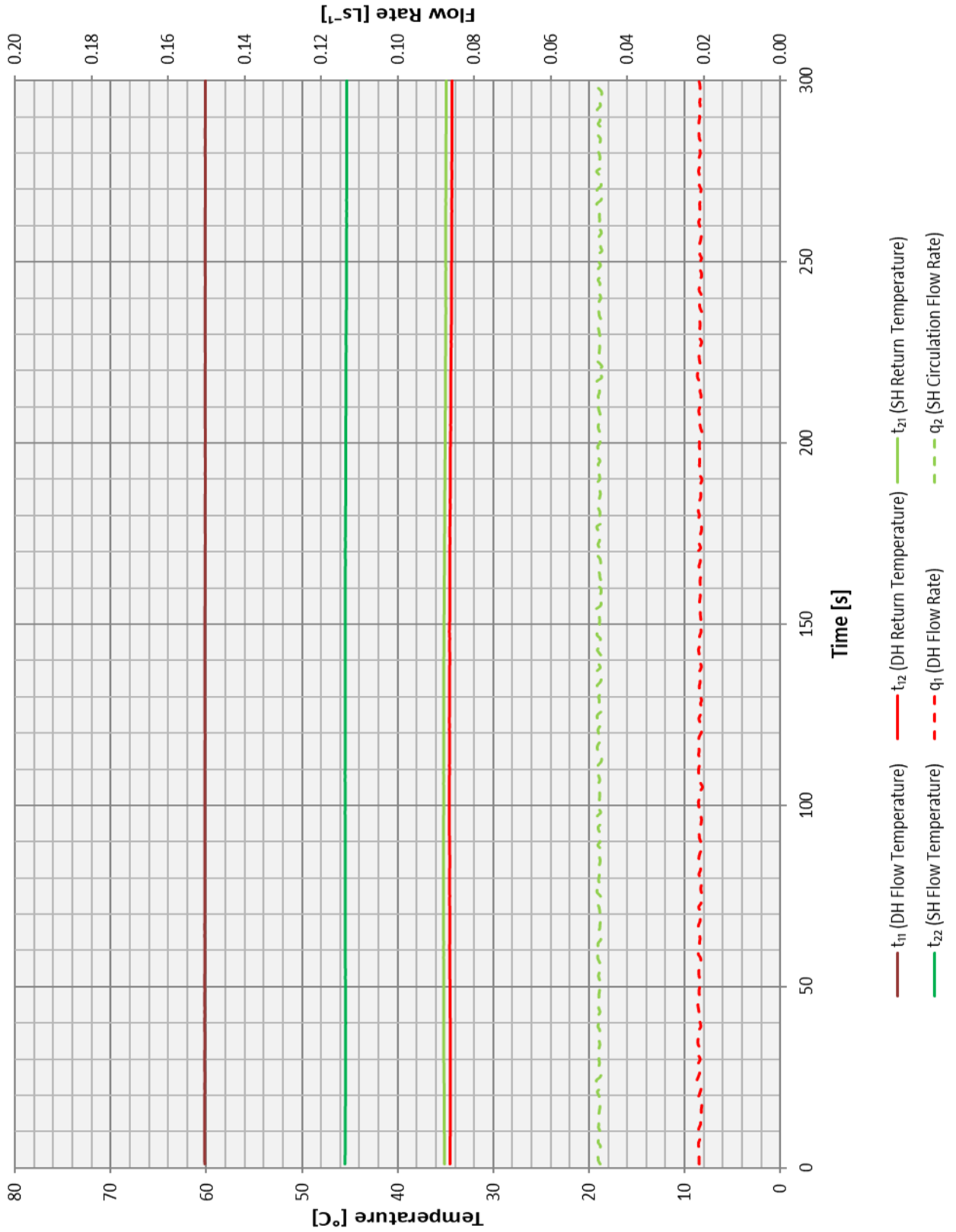

Figure 7.5 - Test 1e – Space Heating 2 kW at 60 °C

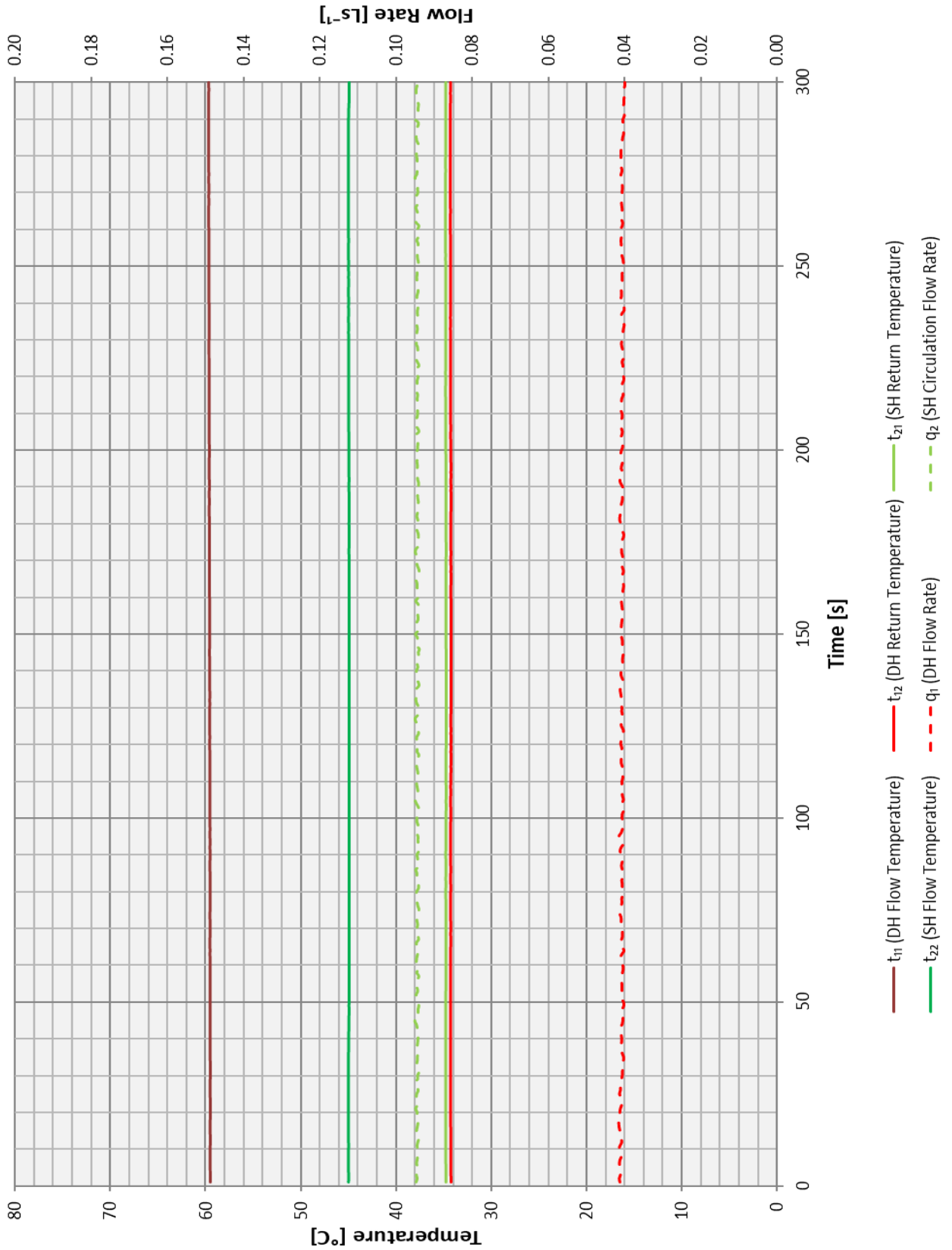

Figure 7.6 - Test 1f – Space Heating 4 kW at 60 °C

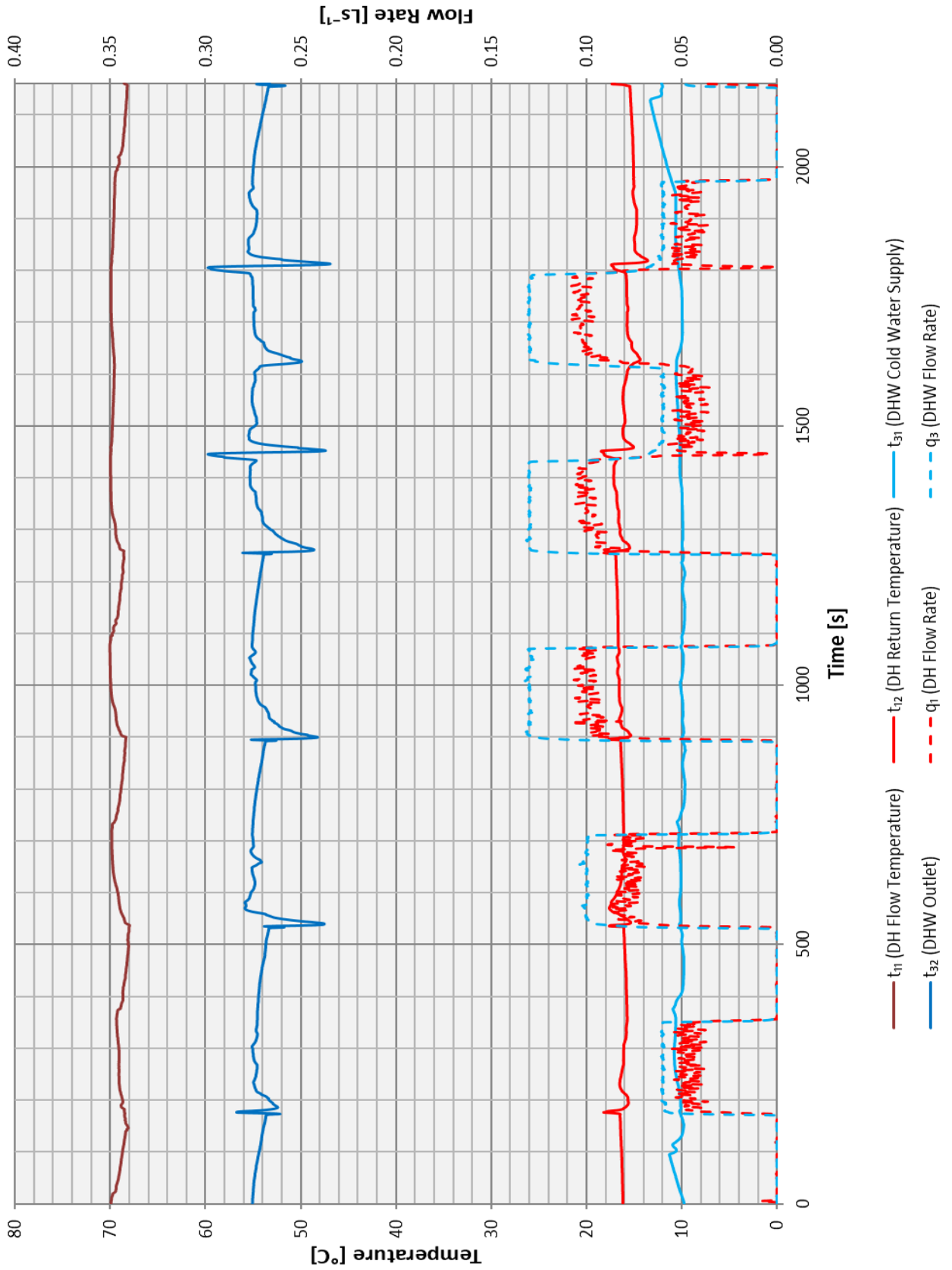

Figure 7.7 - Test 2a – DHW only at 70 °C

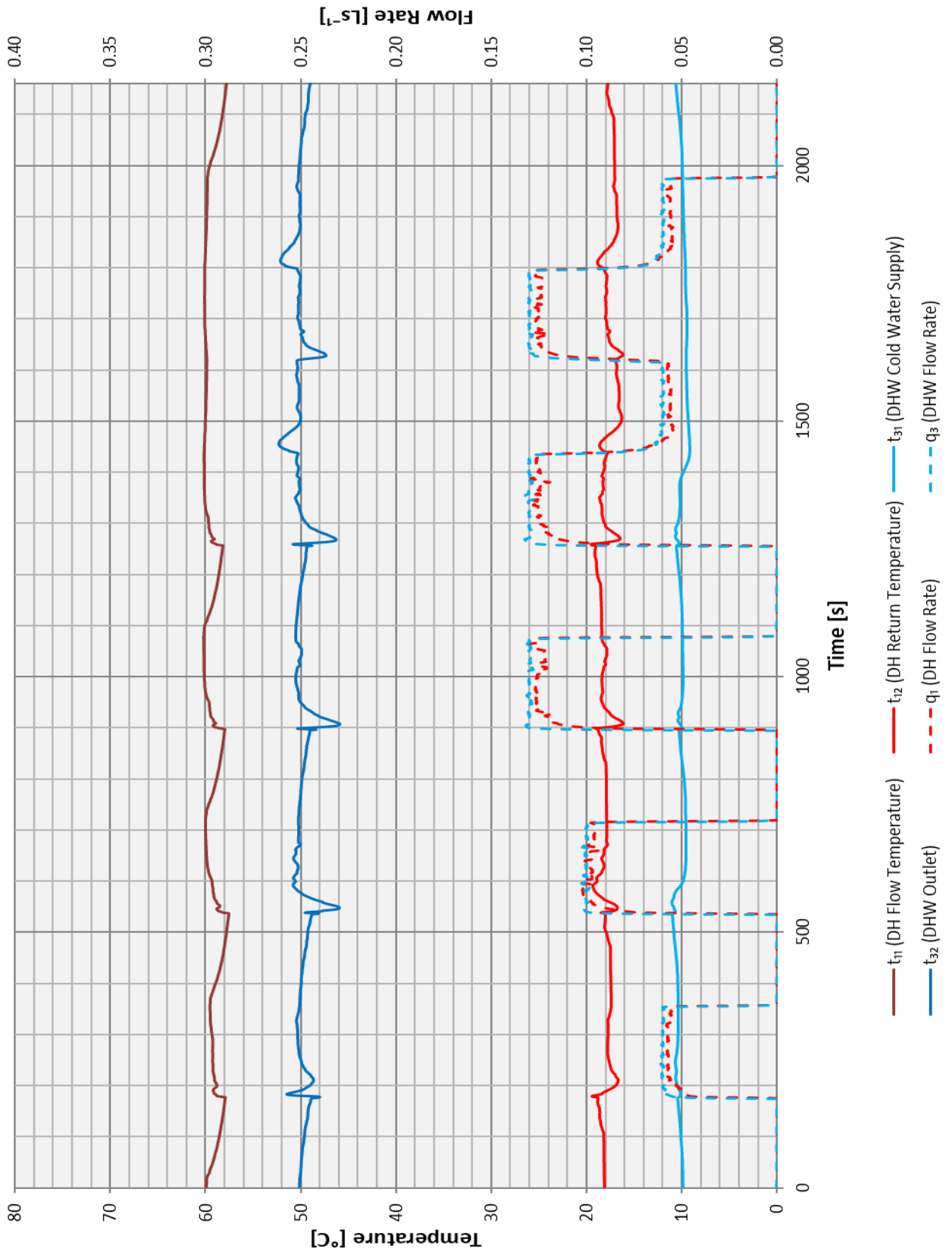

Figure 7.8 - Test 2b – DHW only at 60 °C

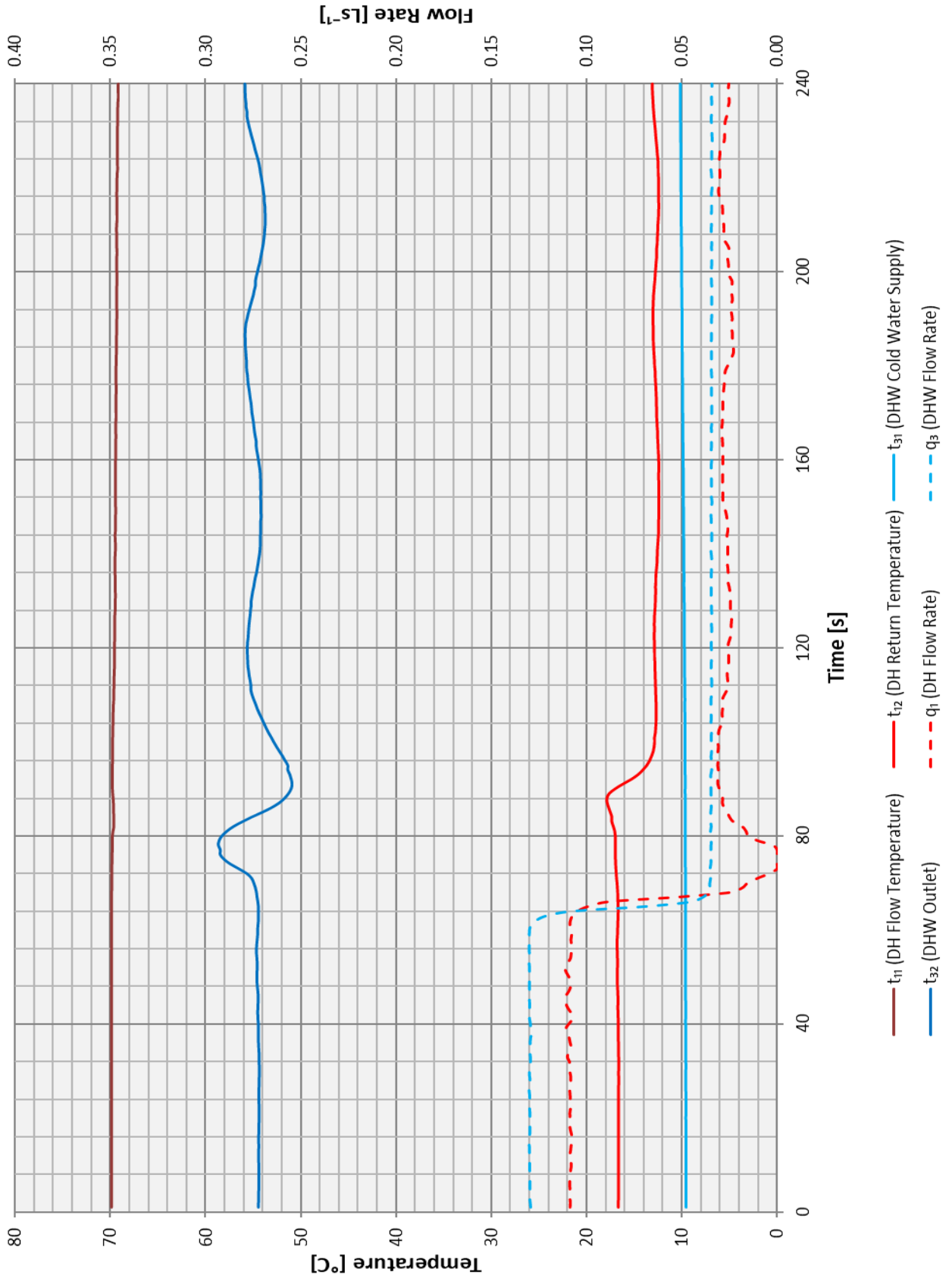

Figure 7.9 - Test 3c – Low Flow DHW at 70 °C

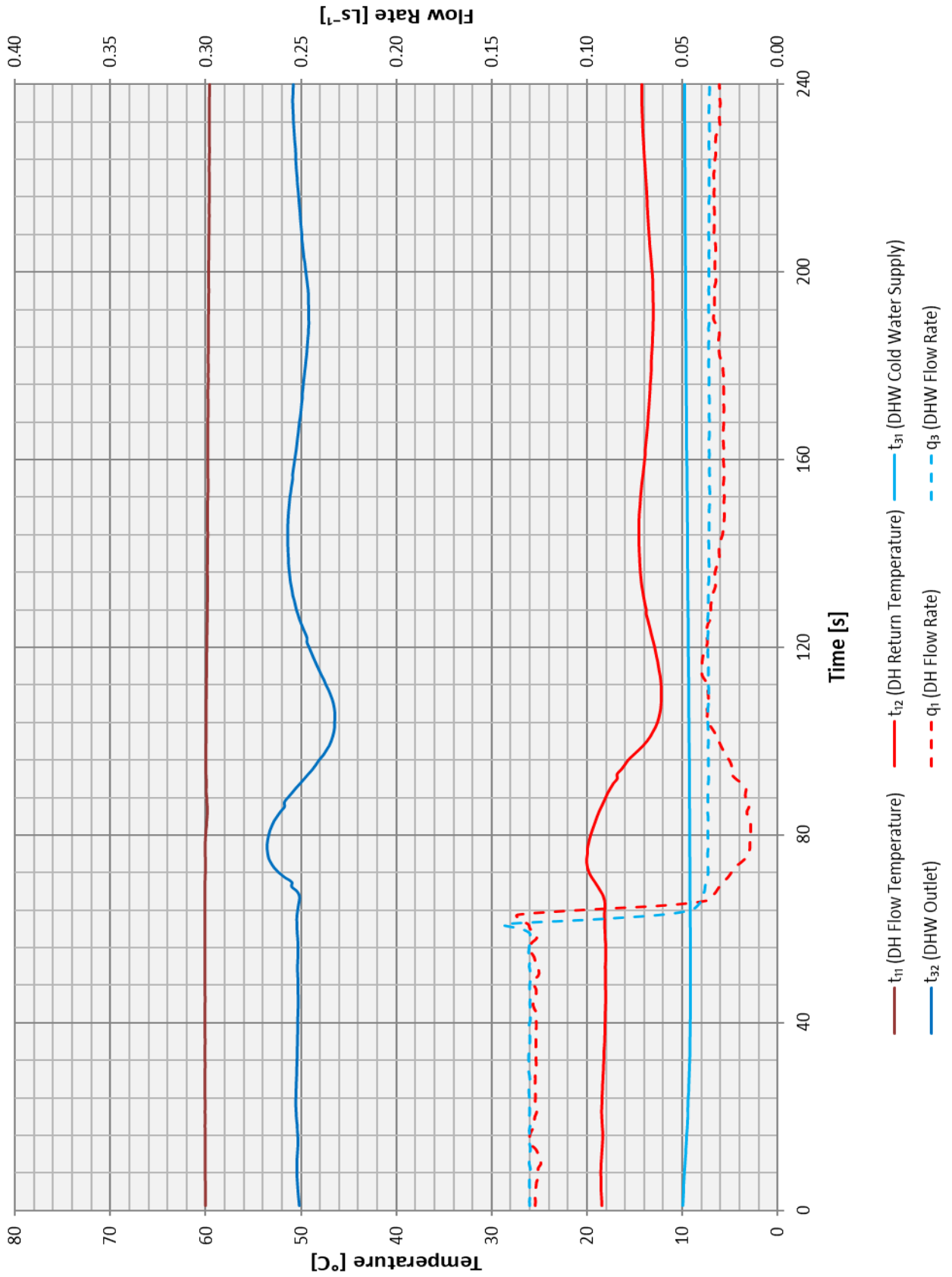

Figure 7.10 - Test 3d – Low Flow DHW at 60 °C

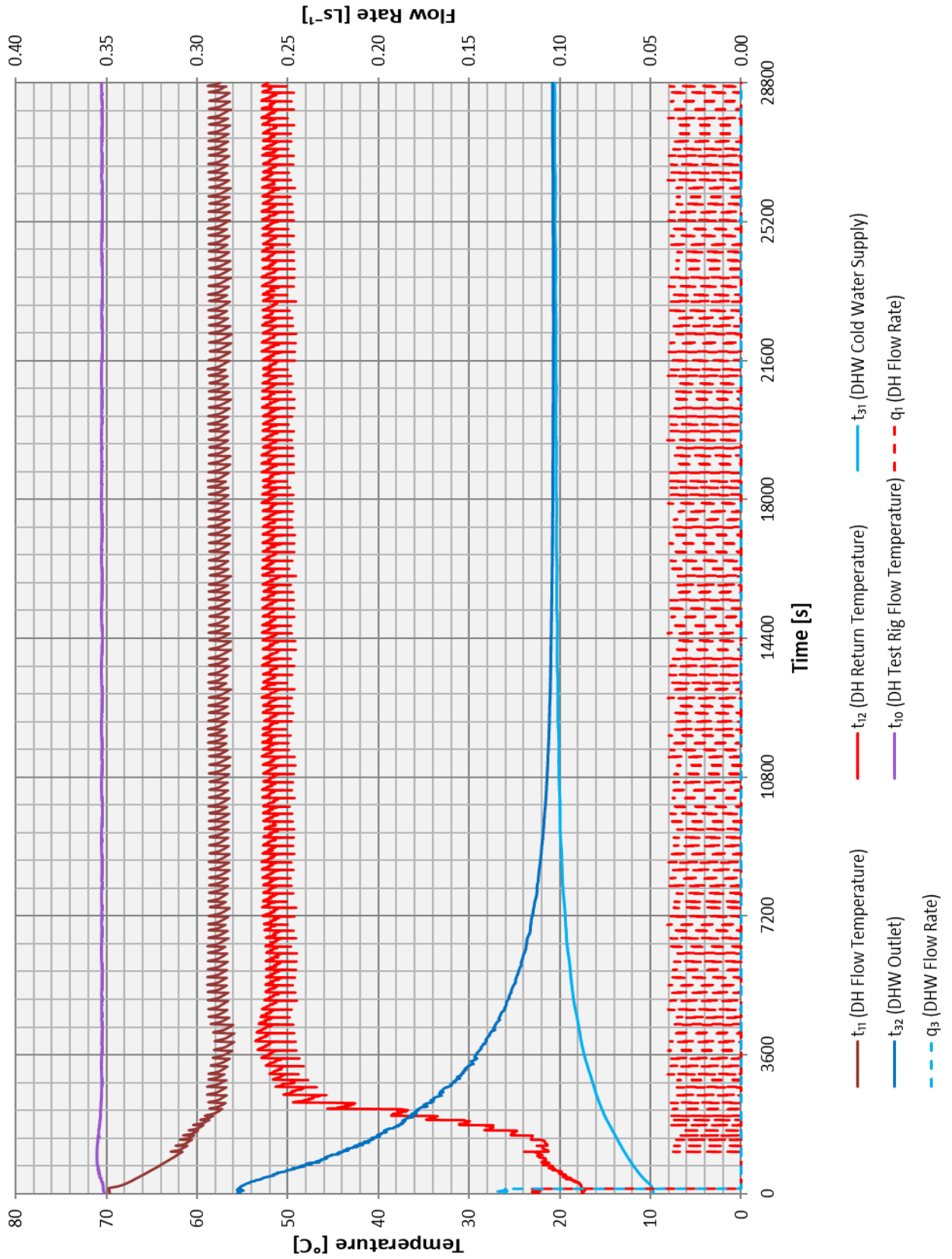

Figure 7.11 - Test 4a – Keep-warm at 70 °C

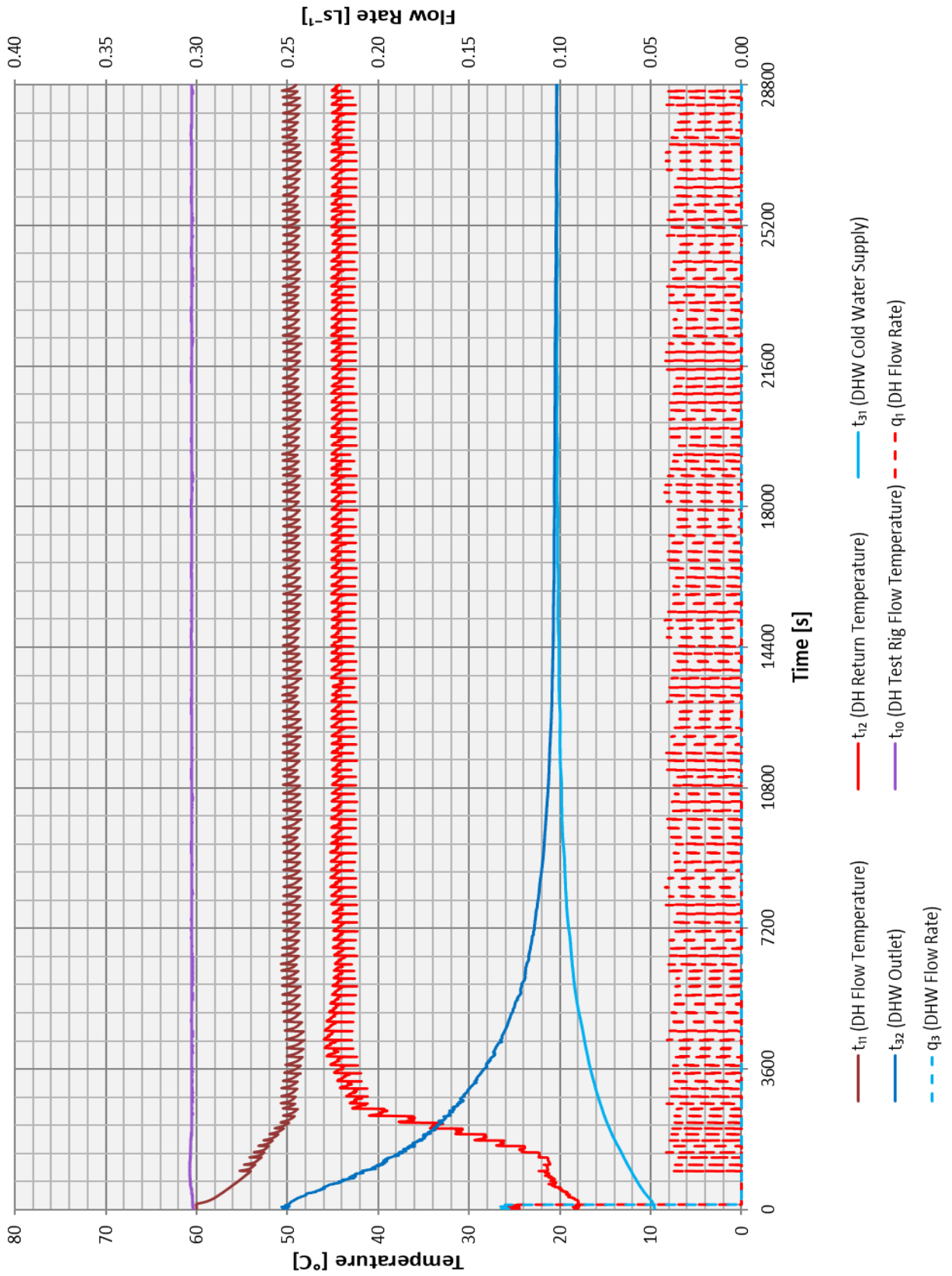

Figure 7.12 - Test 4b – Keep-warm at 60 °C

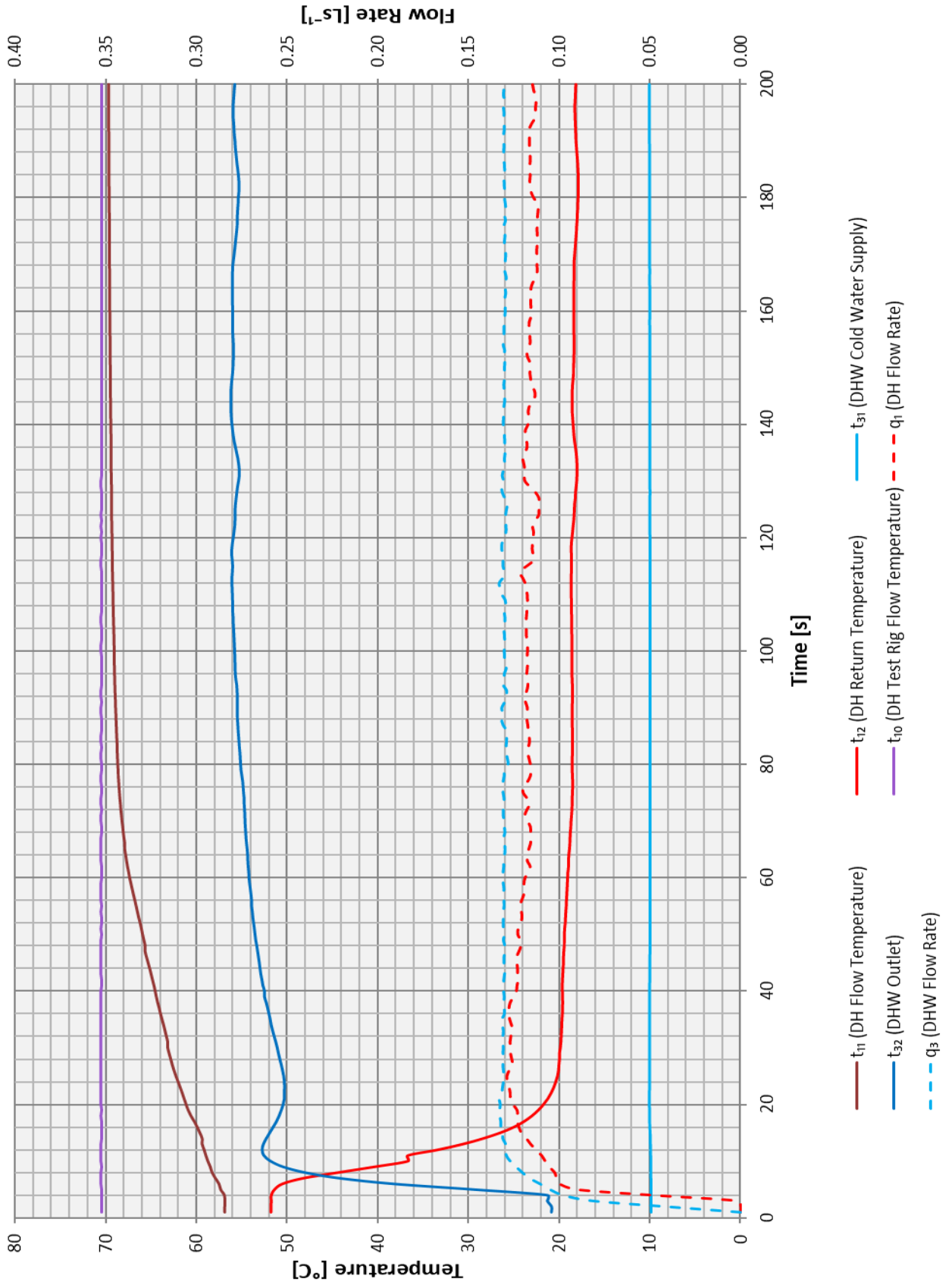

Figure 7.13 - Test 5a – DHW Response Time at 70 °C

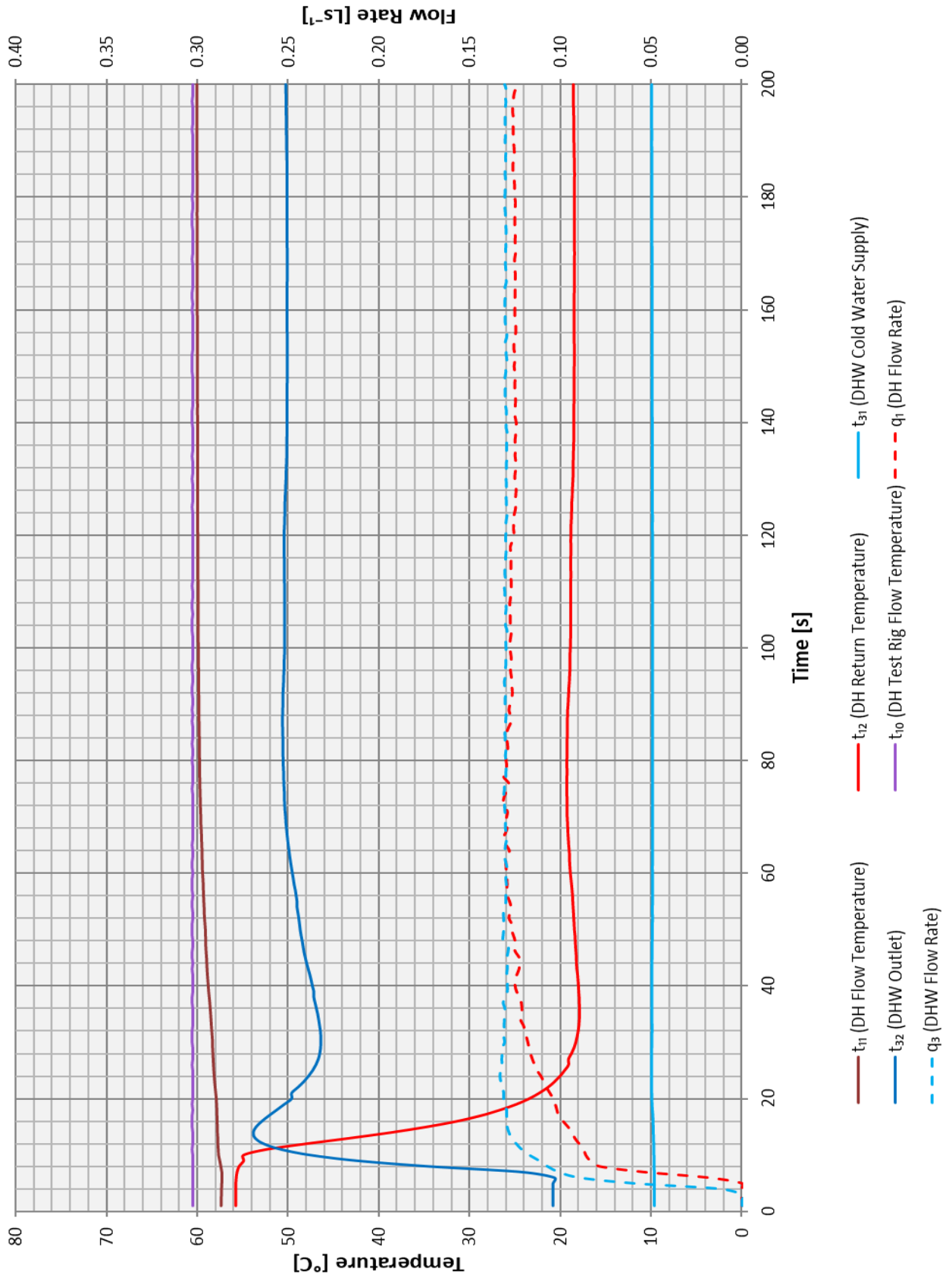

Figure 7.14 - Test 5b – DHW Response Time at 60 °C

7.2 Key Metric and VWARD Summary

7.2.1 The summary tables of the key metrics and VWARDs of the tests described in this report are given in this section.

SUMMARY TABLES START ON NEXT PAGE

Parameter	Symbol	Units	Space Heating						Dynamic Domestic Hot Water						Keep Warm	
			1kW	2kW	4kW	Low Flow	Post Low Flow	Med Flow	Post Med Flow	High Flow	Post High Flow					
			1d	1e	1f	2b	2b	2b	2b	2b	2b	2b	2b	2b	4b	
Volume Weighted Avg. Return Temp	[VMART]	[°C]	34.45	34.45	34.25	17.6	17.4	18.2	17.9	18.0	18.4	43.4				
Annual Hours of Operation	[h]	[hrs]	92	382	141	59	-	14	-	17	-	8056				
Annual Primary Volume	[V]	[m ³]	3.7	29.0	20.6	11.7	0.0	4.9	0.0	7.2	0.0	75.4				
Primary Power	[P ₁]	[W]	1207	2260	4319	9628	3	16555	3	21178	3	70.2				
Secondary Power	[P ₂]	[W]	1070	2059	4020	-	-	-	-	-	-	-				
DHW Power	[P ₃]	[W]	-	-	-	12435	0	20772	0	26727	0	-				
Primary Flow Temperature	[t ₁₁]	[°C]	59.9	60.1	59.6	59.2	59.1	59.5	59.6	59.8	59.8	49.8				
Primary Return Temperature	[t ₁₂]	[°C]	34.4	34.5	34.2	17.6	17.4	18.2	17.9	18.0	18.4	42.8				
Secondary Return Temperature	[t ₂₁]	[°C]	35.1	35.1	34.8	-	-	-	-	-	-	-				
Secondary Flow Temperature	[t ₂₂]	[°C]	45.9	45.5	44.9	-	-	-	-	-	-	-				
DHW Supply Temperature	[t ₃₁]	[°C]	-	-	-	10.5	10.4	10.0	9.6	10.0	10.0	19.1				
DHW Outlet Temperature	[t ₃₂]	[°C]	-	-	-	49.9	50.0	49.9	50.1	49.6	50.4	23.3				
Primary Flow Rate	[q ₁]	[Ls ⁻¹]	0.011	0.021	0.041	0.055	0.000	0.096	0.000	0.121	0.000	0.003				
Secondary Flow Rate	[q ₂]	[Ls ⁻¹]	0.024	0.047	0.094	-	-	-	-	-	-	-				
DHW Flow Rate	[q ₃]	[Ls ⁻¹]	-	-	-	0.059	0.000	0.100	0.000	0.129	0.000	0.000				
Primary Pressure Differential	[Δp ₁]	[kPa]	52.7	55.1	53.1	52	61	50	60	49	60	92				
Secondary Pressure Differential	[Δp ₂]	[kPa]	0.2	1.8	8.5	-	-	-	-	-	-	-				
DHW Pressure Differential	[Δp ₃]	[kPa]	-	-	-	1	0	3	1	4	1	-				
Ambient Temp	[t _a]	[°C]	19.6	20.1	19.5	20.3	20.3	20.3	20.3	20.3	20.3	19.6				

Clause 7.2.1, Table 7.2

Table 7.1 - key metrics of Low Temperature Package

Parameter	Symbol	Units	Space Heating			Dynamic Domestic Hot Water						Keep Warm
			1kW 1a	2kW 1b	4kW 1c	Low Flow 2a	Post Low Flow 2a	Med Flow 2a	Post Med Flow 2a	High Flow 2a	Post High Flow 2a	
Volume Weighted Avg. Return Temp	[VWART]	[°C]	38.16	39.78	40.79	16.1	15.8	16.4	16.1	16.5	16.7	50.5
Annual Hours of Operation	[h]	[hrs]	91	391	145	54	-	13	-	15	-	8050
Annual Primary Volume	[V]	[m ³]	3.3	24.4	17.7	8.8	0.0	3.6	0.0	5.3	0.0	81.8
Primary Power	[P ₁]	[W]	1353	2211	4110	10279	11	17202	39	21954	18	86.3
Secondary Power	[P ₂]	[W]	1079	2011	3900	-	-	-	-	-	-	-
DHW Power	[P ₃]	[W]	-	-	-	13505	0	22485	0	28934	0	-
Primary Flow Temperature	[t ₁₁]	[°C]	70.0	70.3	69.7	69.0	68.9	69.3	69.4	69.6	69.6	57.8
Primary Return Temperature	[t ₁₂]	[°C]	38.2	39.8	40.8	16.1	15.8	16.4	16.1	16.5	16.7	49.8
Secondary Return Temperature	[t ₂₁]	[°C]	40.0	39.9	40.2	-	-	-	-	-	-	-
Secondary Flow Temperature	[t ₂₂]	[°C]	60.3	59.8	60.2	-	-	-	-	-	-	-
DHW Supply Temperature	[t ₃₁]	[°C]	-	-	-	0.0	0.0	0.0	0.0	0.0	0.0	19.4
DHW Outlet Temperature	[t ₃₂]	[°C]	-	-	-	54.5	54.5	54.5	54.9	53.9	55.0	23.8
Primary Flow Rate	[q ₁]	[Ls ⁻¹]	0.010	0.017	0.034	0.045	0.000	0.075	0.000	0.095	0.000	0.003
Secondary Flow Rate	[q ₂]	[Ls ⁻¹]	0.013	0.024	0.047	-	-	-	-	-	-	-
DHW Flow Rate	[q ₃]	[Ls ⁻¹]	-	-	-	0.059	0.000	0.099	0.000	0.128	0.000	0.000
Primary Pressure Differential	[ΔP ₁]	[kPa]	49.4	51.1	51.2	55	72	53	66	54	65	120
Secondary Pressure Differential	[ΔP ₂]	[kPa]	-0.3	0.2	1.8	-	-	-	-	-	-	-
DHW Pressure Differential	[ΔP ₃]	[kPa]	-	-	-	0	0	3	0	5	0	-
Ambient Temp	[t _a]	[°C]	20.4	19.8	20.1	22.6	22.6	22.6	22.6	22.6	22.6	20.1

Clause 7.2.1, Table 7.1

Table 7.2 - key metrics of High Temperature Package

Description	Symbol	Value	Unit
Annual Heating Period Percentage	SH_{PROP}	7.0	%
Annual Non-Heating Period Percentage	NSH_{PROP}	93.0	%
Space Heating Volume Weighted Return Temperature	$VWART_{SH}$	34	°C
DHW Volume Weighted Return Temperature	$VWART_{DHW}$	18	°C
Keep Warm Volume Weight return Temperature	$VWART_{KWM}$	43	°C
Annual Volume Weighted Return Temperature For Heating Period	$VWART_{HEAT}$	35	°C
Annual Volume Weighted Return Temperature For Non-Heating	$VWART_{NONHEAT}$	37	°C
Total Annual Volume Weighted Return Temperature	$VWART_{HIU}$	37	°C

Clause 5.13.1, Table 5.4

Table 7.3 – Low Temperature VWART calculations

Description	Symbol	Value	Unit
Annual Heating Period Percentage	SH_{PROP}	7.2	%
Annual Non-Heating Period Percentage	NSH_{PROP}	92.8	%
Space Heating Volume Weighted Return Temperature	$VWART_{SH}$	40	°C
DHW Volume Weighted Return Temperature	$VWART_{DHW}$	16	°C
Keep Warm Volume Weight return Temperature	$VWART_{KWM}$	51	°C
Annual Volume Weighted Return Temperature For Heating Period	$VWART_{HEAT}$	41	°C
Annual Volume Weighted Return Temperature For Non-Heating	$VWART_{NONHEAT}$	44	°C
Total Annual Volume Weighted Return Temperature	$VWART_{HIU}$	44	°C

Clause 5.13.1, Table 5.3

Table 7.4 – High Temperature VWART calculations



VWART Calculation with Keep Warm

Test carried out by Enertek International for Low Temperature BESA Tests

Manufacturer:

Switch 2 Energy Ltd

Model:

T3 Eco HIU

Serial number:

S2HIU19000576

Calculation performed by B Meekin of Enertek on:

04/08/2019

Primary Flow Temperature: 60°C

DHW Setpoint: 50°C

Space Heating Temperature: 45/35°C

	VWART (°C)	Volume (m³)
DHW	18	23.8
Standby	43	75.4
Space Heating	34	53.3

Period	VWART (°C)	% Time
No Heating	37	93%
Heating	35	7%
Overall	37	

VWART with keep warm <u>NOT</u> active	VWART (°C)	% Time
	18	93%
	34	7%
	19	

	Power [W]	Primary flow [m³/hr]	VWART [°C]	Test Results			Events [Per Year]	Average duration [Seconds]
				Energy Used [kWh]	Annual Operation [Hours]	Volume [m³]		
1kW Space Heating	1207	0.041	34	111	91.6	3.7	-	-
2kW Space Heating	2260	0.076	34	864	382.2	29.0	-	-
4kW Space Heating	4319	0.146	34	607	140.5	20.6	-	-
DHW Low Flow Rate	12435	0.199	18	564	58.6	11.7	-	-
DHW Medium Flow Rate	20772	0.344	18	237	14.3	4.9	-	-
DHW High Flow Rate	26727	0.435	18	352	16.6	7.2	-	-
DHW Post Low Flow Rate	-	0.000	17	-	-	0.0	10000	30
DHW Post Medium Flow Rate	-	0.000	18	-	-	0.0	660	70
DHW Post High Flow Rate	-	0.000	18	-	-	0.0	300	145
DHW Keep Warm Standby	-	0.009	43	-	8056	75.4	-	-

Table 7.5 – Low Temperature VWART Calculations



VWART Calculation with Keep Warm

Test carried out by Enertek International for High Temperature BESA Tests

Manufacturer: Switch 2 Energy Ltd

Model: T3 Eco HIU

Serial number: S2HIU19000576

Calculation performed by B Meekin of Enertek on: 04/08/2019

Primary Flow Temperature: 70°C

DHW Setpoint: 55°C

Space Heating Temperature: 60/40°C

	VWART (°C)	Volume (m³)
DHW	16	17.7
Standby	51	81.8
Space Heating	40	45.4

Period	VWART (°C)	% Time
No Heating	44	93%
Heating	41	7%
Overall	44	

VWART (°C)	% Time
16	93%
39	7%
18	

	Test Results							
	Power [W]	Primary flow [m³/hr]	VWART [°C]	Energy Used [kWh]	Annual Operation [Hours]	Volume [m³]	Events [Per:Year]	Average duration [Seconds]
1kW Space Heating	1353	0.037	38	123	90.8	3.3	-	-
2kW Space Heating	2211	0.062	40	865	391.4	24.4	-	-
4kW Space Heating	4110	0.122	41	595	144.9	17.7	-	-
DHW Low Flow Rate	13505	0.163	16	555	54.0	8.8	-	-
DHW Medium Flow Rate	22485	0.271	16	227	13.2	3.6	-	-
DHW High Flow Rate	28934	0.343	16	337	15.3	5.3	-	-
DHW Post Low Flow Rate	-	0.000	16	-	-	0.0	10000	30
DHW Post Medium Flow Rate	-	0.001	16	-	-	0.0	660	70
DHW Post High Flow Rate	-	0.000	17	-	-	0.0	300	145
DHW Keep Warm Standby	-	0.010	51	-	8050	81.8	-	-

Table 7.6 – High Temperature VWART Calculations

8 APPENDIX B

8.1 Appliance Documentation

8.1.1 The details of the appliance documentation are given in Table 8.1 below.

Table 8.1 – Documentation Supplied

	Component:	Document Submitted (Y/N):	Manufacturer and type:
1	Space Heating Heat Exchanger	Y	Swep B8LASH-1-20 / Switch2 0800050
2	Domestic Hot Water Heat Exchanger	Y	Danfoss XB06H-1-30 / Switch2 0800052
3	Controller for Space Heating	N	Pactrol 433600
4	Control Valve and Actuator for Space Heating	Y	Honeywell VSMF valve w/M64 actuator
5	Space Heating Strainer	N/A	N/A
6	Controller for Domestic Hot Water	N	Pactrol 433600
7	Control Valve and Actuator for Domestic Hot Water	Y	Frese Optima Compact w/Switch2 E1110000 actuator
8	Temperature Sensors	Y	Therm-o-Disc 39J
9	Domestic Hot Water Isolating Valve	Y	Airaga 362 3/4" MM
10	Primary Side Strainer	Y	Switch2 0800022
11	Drain Valves	Y	Embrass 700555
12	Vent Valves	Y	Switch2 0800022
13	Circulation Pump set with AAV & PRV	Y	Wilo Yonos Para MSL7.0 PWM
14	Heat Meter	Y	Landis & Gyr T230
15	Domestic Hot Water Flow Sensor	Y	Honeywell C7195B
16	Pipes	Y	Switch2 0800040
17	Connections	Y	Switch2 0800025-28
18	Joints	Y	Eriks EPDM SSL
19	Gaskets	Y	Novus 20
20	Expansion Vessel	Y	Zilmel OEM-PRO 8L
21	Insulation	Y	Switch2 0800004
22	Pressure Sensors	Y	Huba 505
A1	'O' Ring	Y	Eriks DPDM SSL
A2	Commissioning guide.	Y	HIUPRO130 Switch2 SOP - Type 3 ECO - HIU Commissioning
A3	Operation guides with a function description / description of operation and care instructions as suited to the intended user category.	Y	ECO T3 HIU OM Manual
A4	Declaration of Conformity for CE-marked HIUs.	Y	T3 ECO CE Certificate
A5	Full parameter list for electrically controlled HIUs.	Y	HIUDOC126 ECO HIU T3 Settings Sheet
A6	Maximum primary static operating differential pressure.	Y	T3 ECO Pressure and Soundness Test Declaration
A7	Deactivation procedure of the internal SH pump.		
	Model name and type number	Y	T3 ECO HIU
	Serial number		S2HIU19000576

8.2 Appliance Components

8.2.1 Details of the main appliance components are given in Table 8.2.

Table 8.2 – Appliance Components details

T3 ECO HIU	
Appliance Serial Number	S2HIU19000576
Space Heating Heat Exchanger	Swep B8LASH-1-20 / Switch2 0800050
Domestic Hot Water Heat Exchanger	Danfoss XB06H-1-30 / Switch2 0800052
Controller for Space Heating	Pactrol 433600
Control Valve & Actuator for Space Heating	Honeywell VSMF valve w/M64 actuator
Controller for Domestic Hot Water	Pactrol 433600
Temperature Sensors	Therm-o-Disc 39J
Domestic Hot Water Isolating valve	Airaga 362 3/4" MM
Primary Side Strainer	Switch2 0800022
Circulation Pump	Wilo Yonos Para MSL7.0 PWM
Heat Meter	Landis & Gyr T230
Domestic Hot Water Flow Sensor	Honeywell C7195B
Pipes	Switch2 0800040
Connections	Switch2 0800025-28
`O` Rings	Eriks DPDM SSL
Gaskets	Novus 20
Expansion Vessel	Zilmet OEM-PRO 8L
Pressure Sensors	Huba 505
Insulation	Switch2 0800004

8.3 Appliance Photographs



Figure 8.1 – Photograph of appliance with case off



Figure 8.2 – Photograph of appliance with case on



Figure 8-3 – Data Label

8.4 Calibrations and uncertainties

8.4.1 A list of equipment, their calibrations and uncertainties are given in Table 8.3 below.

Table 8.3 - EIL Equipment Calibration and Uncertainties

Equipment Name	ID Number	Calibration Certificate	Measurement Uncertainty $K=2$ $\frac{U}{\sqrt{20}}$	Units	Calibration Date	Calibration Due
Primary Flow Rate (Badger Flow Meter)	FM 601	U92491-18	±0.0004	l/s	23-05-2018	23/05/2019
DHW Flow Rate (Badger Flow Meter)	FM 602	U92511-18	±0.00305	l/s	24-05-2018	24/05/2019
SH Flow Rate (Badger Flow Meter)	FM 603	U92467-18	±0.04871	l/s	22-05-2018	22/05/2019
DHW Output Pressure Transducer	PT 083	K41129P	±7.73	kPa	22-05-2018	22/05/2019
Cold Water Supply Pressure Transducer	PT 084	K41130P	±7.31	kPa	22-05-2018	22/05/2019
Primary Return Pressure Transducer	PT 085	K41131P	±7.88	kPa	22-05-2018	22/05/2019
Primary Supply Pressure Transducer	PT 086	K41132P	±6.82	kPa	22-05-2018	22/05/2019
SH Flow Pressure Transducer	PT 087	K41127P	±7.26	kPa	22-05-2018	22/05/2019
SH Return Pressure Transducer	PT 088	K41128P	±7.30	kPa	22-05-2018	22/05/2019
SH Return Temp (HIU Inlet)	PRT 4608	EIL 433000	±0.5	°C	19/07/2018	19/07/2019
Primary Supply Temp	PRT 4611	EIL 432360	±0.4	°C	16/05/2018	16/05/2019
Primary Return Temp	PRT 4612	EIL 432360	±0.4	°C	16/05/2018	16/05/2019
SH Supply Temp (HIU outlet)	PRT 4613	EIL 432360	±0.4	°C	16/05/2018	16/05/2019
DHW Output Temp	PRT 4615	EIL 432360	±0.4	°C	16/05/2018	16/05/2019
Cold Water Supply Temp	PRT 4705	EIL 432360	±2.2	°C	16/05/2018	16/05/2019
Software	VERSION – LabVIEW, Version 5 , Service pack 1					

Report Issue No	Reason for Report Update
1	Original Issue

Report Template Issue No	Reason for Report Update
1	Original Issue
1.1	



1 Malmo Road
Sutton Fields
Kingston upon Hull, HU7 0YF

+44 (0) 1482 877500
enertekinternational.com
Registered in England No. 2262638

